

NEW COMBO

2012 Models Edition 2



Proud Sponsor of Home Nations Football



▶ THE WHEELS OF BUSINESS. HELPING YOU DELIVER.

Whatever your line of business, Vauxhall Commercial Vehicles can help you deliver. With five different models – including New Combo and the award-winning Corsavan – we offer a massive choice of almost 300 variants including panel vans, chassis cabs,

crew cabs, platform cabs, tippers, dropsides, box vans and passenger carriers. We're also committed to keeping your business moving. That means reliable, fuel-efficient vehicles – including our new ecoFLEX range – supported by a dedicated network of over



450 retailers offering the expert support and back-up you need. We build more commercial vehicles at our British production facilities at Ellesmere Port and Luton than any other UK manufacturer. We've also won over 30 industry awards since 2001 – major awards,

presented by some of the toughest judges in the business. Introduce the in-built reassurance of the Vauxhall brand and it's easy to see why Vauxhall Commercial Vehicles really are 'The Wheels of Business'.





NEW COMBO. NEW POSSIBILITIES.

Want to give your business a lift? Then get yourself a vehicle that delivers a long list of commercial firsts. Roomy, accessible and loads better in the cargo department, this brilliant new model raises the bar for vehicles in this class. It's also dependable, versatile and efficient to run. And with long wheelbase and high roof models now available, it's more practical than ever. With capabilities such as these, one thing is certain: New Combo really can help your business deliver.

Some of the vehicles shown include options and accessories available at extra cost. And not all of the features described are available on every model. So please check the Equipment and Technical Data section for further details. From time to time we may also offer alternative models such as Special Editions which are featured in separate literature or can be found on the Vauxhall website: www.vauxhall.co.uk/vans

CONTENTS

NEW COMBO

Introduction	6
Cabin	8
Versatility	10
Body styles	12
Load area	14
Practicality and comfort	16
Safety and infotainment	18
Engines and drivetrain	20
Variants	22
New Combo range	24
Options and accessories	28
Colours and trims	30
Equipment	32
Technical data	35





A LOAD OFF YOUR MIND

New Combo is quite simply first class. Not only does it have one of the longest and most spacious load areas in its class, but it also has the highest rear axle weight and the largest rear door opening; combined with a useful, low rear loading height. When it comes to key business tools, you always invest in the best. In both the long and short term, that makes it a seriously good investment.

A weighty proposition. The benefits don't end there. New Combo can haul up to a tonne. Yet it boasts ultra-low fuel consumption figures – most notably on the ecoFLEX 1.3 turbo diesel engine with Start/Stop technology. It also has the longest wheelbase in its class, promoting excellent driveability. That's quite a combination and one less thing for business operators to worry about.

A COMFORTABLE WORKPLACE

New Combo has all the creature comforts needed to create the ideal working environment. The fascia is clearly laid out, switches easy to reach and controls easy to operate. And with reach- and rake-adjustable steering and a four-way adjustable driver's seat, you can quickly achieve the most comfortable driving position. Better still, the high-set seating provides an excellent view of the road. Other standard features include a fully-featured CD player/radio, while a broad choice of options – including sat nav and Bluetooth® – let you fine-tune your working environment with the business tools you need. New Combo is also packed with practical stowage solutions that make light work of organising your cab. Sportive and all high-roof models feature an overhead storage facility that's ideal for holding folders, worksheets and items you need close at hand.





A PRACTICAL PERSPECTIVE

Reduce your overheads and increase your potential for growth. With its high capacity and low running costs, New Combo really can give your business a competitive edge. As an all-new vehicle, every opportunity has been taken to totally rethink the cab environment, as well as the cargo area. At the business end, a range of custom-fit options allow you to transport all manner of loads, efficiently and safely – from parcels and pipes to ladders and larger items of equipment. Even with heavy machinery on board, the handling stays sharp and the ride comfortable. All of which means that New Combo appeals more than ever to today's business user.





Instant access. New Combo is big on convenience. Offside and nearside sliding side-access doors are fitted to all long wheelbase models; a nearside sliding side-access door is also standard on short wheelbase Sportive models. Together, the doors add even greater loading versatility to New Combo's load carrying potential, while allowing convenient access to cargo via the side of the vehicle. This is a particular benefit where the need arises for access to the offside of the vehicle. A glazed side door option is also available.



BUILT BY EXPERTS FOR EXPERTS



Whatever your trade, there's a New Combo that gets the job done. Now with three distinct body styles – offering a choice of long or short wheelbases and high or standard roof heights – the new range lets you select the configuration that's the exact fit for your business, meeting your requirements more closely than any previous Combo model. And whichever version you choose, our design experts have ensured that your New Combo will always be fit for purpose – a factor reinforced by a wide range of options and accessories. So whichever way you look at it, choosing New Combo is a win-win decision.

➤ LOADED WITH INNOVATION

At a massive 3.4cu.m for the short wheelbase, standard roof version, there's no mistaking New Combo's cavernous load area. The biggest cargo space in its sector will comfortably swallow everything from Euro pallets to plant equipment and heavy machinery. For even bigger items, there's a high roof or long wheelbase version: the latter variant packs in an impressive 4.2cu.m while the maximum load height of high roof models is over 1.5 metres. Adding to the vehicle's appeal are a wide range of load area options – including a handy load flap and internal ladder carrier – which let you exploit New Combo's remarkable carrying potential to the full.

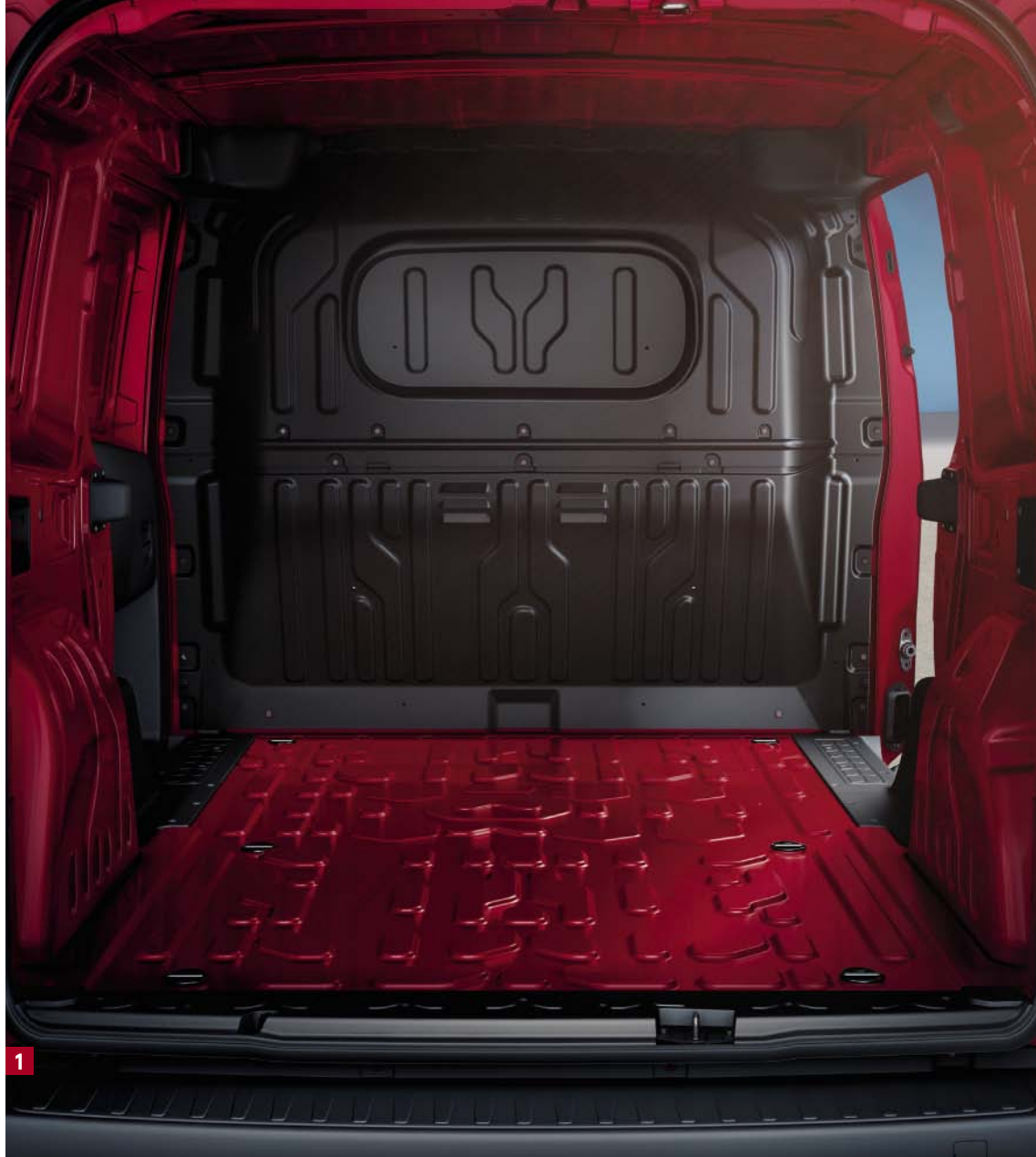



Load up. Open the rear doors of the short wheelbase model and you're looking at a record holder. Quite simply, it has the biggest payload in its class. It also boasts one of the longest and most spacious cargo areas plus a low rear loading height, so there's less risk of straining your back while working.

1. Full-height bulkhead. A full-height steel bulkhead – with optional glazing **2.** – provides valuable protection against shifting loads, while glazed rear door options enhance rear visibility.

3. Rear side panel storage. A storage bin located above the rear wheel arch provides handy stowage for loose items.

4. Load flap. The optional load flap is ideal for accommodating extra long or tall items. Simply unfasten the latch located underneath the flap and the rear section opens, up to an angle of 46°. This provides a handy 916mm x 503mm aperture.

5. Ladder carrier. Fit these optional bars in your van and you can fix a foldable ladder out of sight under the roof where it won't get in the way of your other gear.

➤ EASY DOES IT

From electric windows and air conditioning through to sliding side-access doors, the New Combo range is simply packed with features designed to make the driver's job that bit easier. The key words are practicality and comfort. Options like cruise control, rear parking distance sensors and Electronic Climate Control further enhance driver well-being. The result: a mobile working environment you really won't mind spending time in.

1. Asymmetrical rear doors. New Combo comes with asymmetrical rear doors as standard, which can be specified glazed. **2.** H1 models can also be ordered with a glazed tailgate. Both extra cost, the glazing options feature wiper(s) and heated rear window, and must be ordered in conjunction with the glazed bulkhead option. The standard offer can be the more practical proposition when access to the load area through the rear doors is limited (for example, when operating in tight space). In both instances, the extra-low sill height (just 545mm) makes for ease of loading and unloading.

3. Clean design. New Combo's fascia is clearly and simply laid out, with controls easy to reach and just as easy to operate. Switchgear is logical and the high-mounted driver's seat provides an excellent all-round view of the road.



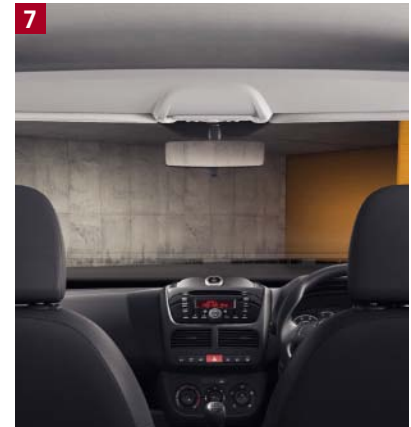

4. Electronic Climate Control (ECC). Optional on Sportive models in conjunction with the Winter Pack, the ECC system features individual temperature controls for the driver and passenger. The Winter Pack itself comprises headlight washers, front fog lights, exterior temperature sensor and electrically adjustable door mirrors.

5, 6 and 7. Practical storage features. New Combo is full of practical storage features to assist with keeping the cabin safe and tidy, such as lockable glovebox and door pockets. While Sportive and all high-roof models feature a handy overhead storage shelf which creates valuable additional space for odds and ends and loose items.

8. Adjustable driver's seat. New Combo models feature a four-way adjustable driver's seat with adjustment fore and aft plus tilt. The six-way adjustable 'Comfort' driver's seat (illustrated right) on Sportive models adds height and lumbar adjustment plus a handy armrest.

SAFE AND SOUND

Safety in the workplace is a vital concern for any business and New Combo is no exception. The protection starts with a sturdy passenger cell made of high-grade steel, plus an airbag for the driver and ABS with Electronic Brakeforce Distribution. Key safety options include driver aids like ESP with Hill Start Assist and rear parking distance sensors, along with passenger and side-impact airbags.

An informed driver is a safer driver, so New Combo can also be specified with an optional CD/MP3 CD player/stereo radio, along with wireless Bluetooth® connectivity for ease of communication on the move and provision for a satellite navigation system to keep you heading in the right direction.

1. Hill Start Assist. Maintains the brake pressure for a short period after the brake pedal has been released when pulling away on a gradient of 5% or more; this helps prevent the vehicle from rolling back. The pressure is released as soon as the driver presses the accelerator and the car begins to move forward. This ensures improved hill starting for increased comfort and safety. Optional on all models.

2. Rear parking distance sensors. Optional rear parking distance sensors provide an audible warning to help prevent accidental damage when parking or reversing.

3. Four airbags. A driver's airbag is standard on all models with the option to add a passenger airbag and side-impact airbags for improved protection in the event of a collision.

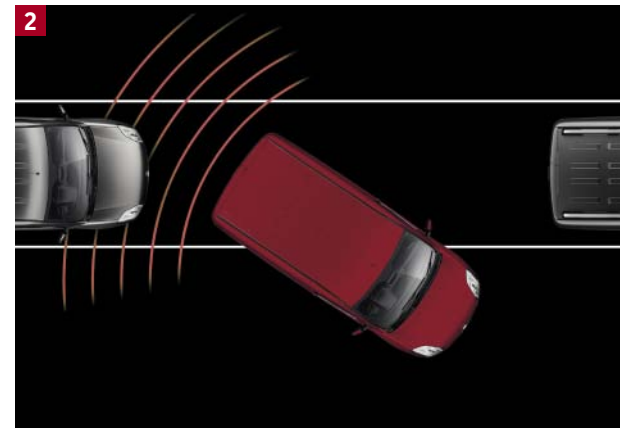
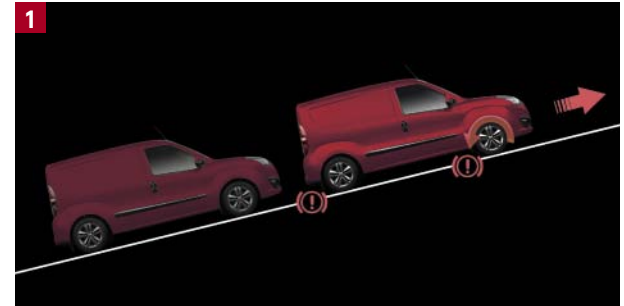



Driver Pack. Drivers looking to create the ultimate working environment can specify the optional Driver Pack at extra cost. The pack comprises a CD/MP3 CD player/stereo radio with Bluetooth® connectivity, aux-in socket, USB port, steering wheel mounted audio controls, leather-covered steering wheel and gear knob (manual models only) along with pre-installation for a TomTom navigation system.

4. Steering wheel-mounted audio controls. Allows you to access all the functions of the optional CD 50 unit without taking your eyes off the road – or your hands off the wheel. You can adjust speaker volume and the text message read-out, accept incoming calls or set voice recognition and stereo options.

5. Aux-in socket and USB port. Conveniently situated for optimum ease of use, the optional aux-in and USB port enable drivers to connect their mobile devices and so access a range of multimedia files, including MP3, MP4 and WMA.

6. CD 50 with multimedia reader. This optional hands-free system incorporates Bluetooth® technology, an SMS message reader and a CD/MP3 CD player/stereo radio. It can access MP3 players and other devices via the aux-in socket and USB port.

TomTom pre-installation kit. Also part of the Driver Pack, provides the essential wiring for a TomTom navigation system (navigation system not included).

➤ POWER AND EFFICIENCY

How well a vehicle holds a load is one thing.
How well it shifts that load is another...

When it comes to everyday driving, New Combo's bi-link independent rear suspension gives you the best possible ride quality and handling – even when you're hauling heavy loads. But New Combo doesn't only ride and handle like a dream; it also performs with remarkable verve for what is, to all intents and purposes, a working vehicle. Drivers can select from four powerful yet efficient Euro 5 compliant turbo-diesel engines and, for the first time, a new 1.4i 16v (95PS) Start/Stop petrol unit. All five engines are designed for optimum ease of serviceability and low running costs. The diesel range comprises 1.3CDTi 16v (90PS),

1.3CDTi 16v (90PS) ecoFLEX Start/Stop, 1.6CDTi 16v (105PS) Start/Stop and 2.0CDTi 16v (135PS) Start/Stop units. There is also a 1.6CDTi 16v (90PS) version complete with Start/Stop and Tecshift transmission. Start/Stop switches the engine off when you stop at the lights or in traffic, then restarts it once the clutch is depressed, cutting fuel bills and reducing emissions. A choice of ecoFLEX models further underlines Vauxhall's 'eco' credentials, while New Combo drivers can also look forward to long service intervals (up to 21,000 miles or one year) and excellent fuel consumption for the 1.3CDTi 16v (90PS) ecoFLEX engine with Start/Stop.

ENGINES AND TRANSMISSIONS

	Maximum power	Maximum torque	Fuel economy mpg (litres/100km)			CO ₂ emissions (g/km)
			Urban driving	Extra-urban driving	Combined figure	
Petrol						
1.4i 16v (95PS) Start/Stop	95PS (70kW) @ 6000rpm	127Nm (94 lb.ft) @ 4500rpm	29.1 (9.7) – 30.7 (9.2)	47.9 (5.9) – 49.6 (5.7)	38.7 (7.3) – 40.3 (7.0)	168 – 163
Diesel						
1.3CDTi 16v (90PS)	90PS (66kW) @ 4000rpm	200Nm (148 lb.ft) @ 1500rpm	42.8 (6.6) – 43.5 (6.5)	65.7 (4.3) – 67.3 (4.2)	55.4 (5.1) – 56.5 (5.0)	136 – 133
1.3CDTi 16v (90PS) ecoFLEX Start/Stop	90PS (66kW) @ 4000rpm	200Nm (148 lb.ft) @ 1500rpm	47.1 (6.0) – 47.9 (5.9)	65.7 (4.3) – 67.3 (4.2)	57.6 (4.9) – 58.9 (4.8)	129 – 126
1.6CDTi 16v (105PS) Start/Stop	105PS (77kW) @ 4000rpm	290Nm (214 lb.ft) @ 1500rpm	44.8 (6.3) – 46.3 (6.1)	55.4 (5.1) – 61.4 (4.6)	51.4 (5.5) – 54.3 (5.2)	146 – 136
1.6CDTi 16v (90PS) Start/Stop Tecshift	90PS (66kW) @ 4000rpm	290Nm (214 lb.ft) @ 1500rpm	50.4 (5.6) – 51.4 (5.5)	54.3 (5.2) – 61.4 (4.6)	53.3 (5.3) – 57.6 (4.9)	140 – 130
2.0CDTi 16v (135PS) Start/Stop	135PS (99kW) @ 3500rpm	320Nm (236 lb.ft) @ 1500rpm	43.5 (6.5)	55.4 (5.1)	50.4 (5.6)	148

For full model availability please refer to the Commercial Vehicle Price Guide available from your Vauxhall retailer or online at vauxhall.co.uk

Tecshift transmission. Tecshift offers all the main features and flexibility of a regular automatic, plus the performance and control of a 'one-touch' manual gearbox.



Sportive model illustrated features roof rails and 16-inch alloy wheels, optional at extra cost.

THE COMBO COLLECTION

Whatever your line of business, whatever cargo you're carrying, there's a New Combo to suit all operators – and all budgets. The choice is entirely down to you. Here's a brief overview of the wide range of models available.

To help you select the New Combo that's just right for your business, we've adopted a new, customer-friendly naming scheme. L stands for Length: there are two versions available, L1 (short wheelbase) and L2 (long wheelbase). Height (H) comes in two sizes, H1 (standard roof) and H2 (high roof). For details of the complete model line-up, please refer to the Commercial Vehicle Price Guide available from your Vauxhall retailer or online at: www.vauxhall.co.uk

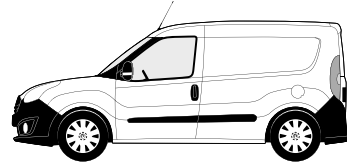

L1 H1: New Combo with short wheelbase and standard roof.

The consummate all-rounder, with up to 3.4cu.m of loadspace. Note: the load area is one of the widest and longest in its class.

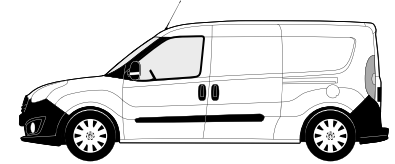

L2 H1: New Combo with long wheelbase and standard roof.

The 3.1m wheelbase gives you up to 4.2cu.m of cargo volume.

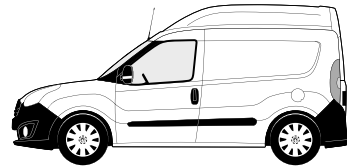

L1 H2: New Combo with short wheelbase and high roof. The high and the mighty, with 4.0cu.m of loadspace.

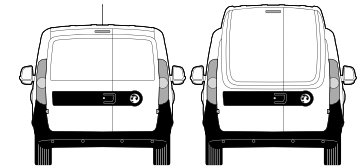

New Combo with standard or high roof. The high roof adds an extra 25cm compared to the standard version.

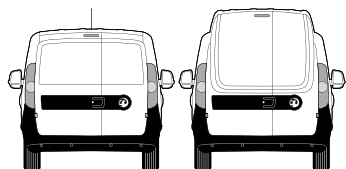

New Combo, a choice of rear doors.

New Combo comes with asymmetrical rear doors as standard or can be ordered with a tailgate option complete with a wiper and a heated rear window as an extra cost option.

Glazing options. Fixed glazed windows for the nearside sliding side-access door and opposite panel or door are available as an extra cost option. In addition, the standard, unglazed asymmetric rear doors are available glazed as an extra cost option and come complete with wipers and heated rear windows.

LOAD AREA DIMENSIONS			
	L1 H1	L1 H2	L2 H1
Loadspace mm (inches)			
Maximum length	1820 (71.7)		2170 (85.4)
Maximum width	1714 (67.5)		
Maximum width between wheel arches	1230 (48.4)		
Maximum height	1305 (51.4)	1550 (61.0)	1305 (51.4)
Side and rear load door dimensions mm (inches)			
Side door aperture height	1175 (46.2)		
Side door aperture width	700 (27.5)		
Rear door aperture height	1250 (49.2)	1455 (57.2)	1250 (49.2)
Rear door aperture width	1231 (48.5)		
Loading heights (unladen) mm (inches)			
	545 (21.4)		
Loadspace volumes cu.m (cu.ft.)			
	3.4 (121)	4.0 (141)	4.2 (148)
Weights and towing (kg)			
Maximum payloads	705 – 1000		
Maximum gross combination weights	2990 – 3500		

COMBO

Known simply as Combo, the base model features stylish good looks while providing a well-equipped and cost-efficient introduction to the line-up.

Standard features include:

- Anti-lock Braking System with Electronic Brakeforce Distribution
- Driver's airbag
- Seatbelt pretensioner system
- Remote control central deadlocking
- Lockable fuel filler cap
- Electronic engine deadlock immobiliser
- Lockable glovebox
- CD player/radio with four 20-watt speakers
- Reach and rake-adjustable steering column
- Reach and rake-adjustable seats
- Cube cloth seat trim
- Overhead shelf (H2 models only)
- Electrically operated front windows
- Body side-protection mouldings
- Windscreen wipers with variable intermittent facility
- Unglazed asymmetric rear doors
- Full-height steel bulkhead
- Load restraint lashing eyes
- Illuminated load area
- Nearside/offside sliding side-access doors (L2 models only)
- 15-inch steel wheels with centre covers (2000 models)
- 16-inch steel wheels with centre covers (2300 models)





ENGINES/TRANSMISSION

- 1.4i 16v (95PS) Start/Stop
- 1.3CDTi 16v (90PS)
- 1.3CDTi 16v (90PS) ecoFLEX Start/Stop
- 1.6CDTi 16v (90PS) Start/Stop Tecshift
- 1.6CDTi 16v (105PS) Start/Stop

Combo 1.6CDTi 16v Start/Stop Tecshift model illustrated left features vinyl seat trim, optional at extra cost.



1. Reach- and rake-adjustable

steering. Reach- and rake-adjustable steering is fitted as standard, ensuring a perfect driving position.

2. Electric windows and central

door locking. Electric windows and central door locking are also standard, promoting security, comfort and convenience. The central locking system features security deadlocks for added protection.

➤ COMBO SPORTIVE

Available for the first time as a trim level on Combo, Sportive models combine additional driver comfort with a highly individual style.

Additional features over and above

Combo models:

- Air conditioning
- Height-adjustable driver's seat with armrest and lumbar support
- Overhead shelf
- Soundproofed bulkhead
- PVC load floor covering
- Nearside sliding side-access door (L1 models only)
- Body-colour front and rear bumpers
- Body-colour exterior door mirrors
- Metallic paint
- 15-inch steel wheels with full-diameter wheel trims (1.3CDTi and 1.6CDTi 2000 models)
- 16-inch steel wheels with full-diameter wheel trims (2.0CDTi and 2300 models)





ENGINES/TRANSMISSION

- 1.3CDTi 16v (90PS)
- 1.3CDTi 16v (90PS) ecoFLEX Start/Stop
- 1.6CDTi 16v (105PS) Start/Stop
- 2.0CDTi 16v (135PS) Start/Stop

2.0CDTi 16v (135PS) Start/Stop model illustrated. Passenger and side airbags are optional at extra cost



1. Overhead storage shelf.

Handy overhead storage shelf creates valuable additional stowage space for odds and ends and loose items.

2. Height-adjustable driver's seat.

Six-way adjustable seat features adjustment fore and aft plus tilt and height adjustment, armrest and lumbar support.

➤ OPTIONS AND ACCESSORIES

Vauxhall options and accessories are all about choice – selecting your New Combo then personalising it to suit the way you work. There's a choice of factory-fitted options and a huge range of Genuine Vauxhall Accessories – all designed and manufactured to the same exacting standards as the van itself. For further information please ask your Vauxhall Commercial Vehicle retailer.

OPTION PACKS:

Driver Pack.

For details see page 19.

Load Compartment Pack.

- 12-volt accessory socket in load area **1.**
- Removable courtesy light in load area **2.**
- Overhead shelf **3.**
- PVC load floor covering

Winter Pack.

- Headlight washers
- Front fog lights **4.**
- Exterior temperature sensor
- Electrically adjustable door mirrors **5.**

INDIVIDUAL OPTIONS INCLUDE:

- Active-safety head restraints
- Alarm pre-installation kit
- Third key/third key with remote control
- Air conditioning
- Electronic climate control
- Cruise control
- Height-adjustable driver's seat with armrest and lumbar support
- Rear parking distance sensors
- Roof rails (H1 models only)
- Protective ladder-frame behind driver in lieu of full-height steel bulkhead
- Uprated alternator
- 16-inch alloy wheels (Sportive only)
- Winter tyres



Genuine Vauxhall Accessories are the right choice for your New Combo. Whatever your business requirement there's certain to be a Vauxhall accessory that fits your need, all fitted by trained Vauxhall professionals. The products shown here are just a small sample of the range available. For a full list, please refer to the Vauxhall Commercial Vehicle Price Guide or visit our website at: www.vauxhall.co.uk/accessories



6. Roof rack tray. Ensures all items carried on the roof are kept safe and secure. Features a load roller to assist in loading heavy and/or long items.

7. Roof base carrier. Our roof rack system begins with this versatile base carrier, comprising three lockable T-track bars. Compatible with a wide range of Thule attachments. Easy to fit and remove.

8. Thule ladder tilt and side profiles with load stop. A special extension bar reaches down over the side of the van so you can quickly load and unload a ladder without stretching. The side profiles with load stop enable large diameter loads of over three metres to be carried safely. Strong ratchet tie downs are provided with both systems.

9. Rear window protection grilles. Help avoid theft while retaining rearward visibility. Can also prevent incidental damage caused by shifting loads.

10. Load area protection panels. Shaped to fit over the floor and side panels to protect the load area.

Towing hitch. We offer a wide choice of towing hitches, from fixed and removable designs to heavy-duty tow hooks and flange balls.

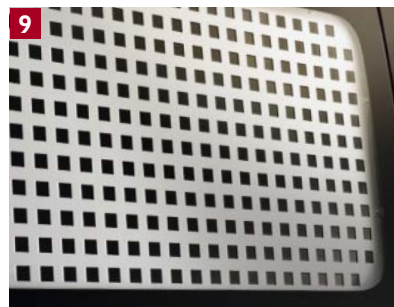

➤ COLOURS AND TRIMS

New Combo's business-like appearance is exemplified by the smart choice of colours available for the new vehicle. The cloth or vinyl trims have been chosen as much for their hard-wearing properties as they have for their strong visual appeal.



Due to the limitations of the printing process, the colours reproduced may vary slightly from the actual paint colour and trim material. As a result, they should be used as a guide only. Your Vauxhall retailer has a comprehensive display of our paint samples and trim swatches.



TRIMS



Cube Cloth



Vinyl**

Black vinyl.** Black vinyl trim can be specified at extra cost for customers requiring a more workmanlike, wipe-clean alternative to cloth.

EXTERIOR COLOURS

	Trim name and trim colour	
	Cube Cloth	Vinyl**
Solid		
Polar White	Black	Black
Tomato Red	Black	Black
Deep Blue	Black	Black
Two-coat metallic*		
Ruby Red	Black	Black
Twilight Blue	Black	Black
Marine Blue	Black	Black
Magnetic Silver	Black	Black
Midnight Black	Black	Black
Pepperdust	Black	Black

* = Optional at extra cost on Combo models. No cost option on Sportive models.

** = Vinyl trim optional at extra cost on Combo models. Not available on Sportive models.

Contents

Equipment

Safety	32
Security	
Facia, instruments and controls	
Seating	
Audio, communication and navigation	33
Interior	
Mechanical	
Exterior	
Load area	34
Wheels and tyres	
Option packs	
Technical data	
Engines	35
Transmission ratios	
Vauxhall Assistance and warranties, insurance groups, transmissions, steering, suspension, brakes, electrics, body and fuel tank capacity	36
Weights and towing data	37
Dimensions, loadspace dimensions, loadspace volume	38
Fuel economy and emissions	39
Glossary of terms	

Safety

Standard features • Daytime running lights • Anti-lock Braking System (ABS) with Electronic Brakeforce Distribution (EBD) • **Emergency Brake Assist (EBA)** – Increases applied brake force in emergency braking situations • **Driver's airbag** • **Height-adjustable head restraints** • **Height-adjustable inertia-reel lap and diagonal seatbelts** • **Seatbelt pretensioner system** – Tightens the seatbelt during the early stages of a frontal impact • **Front seatbelt force limiters** – Reduces potential upper body injuries during a frontal impact • **Side-impact protection beams** • **Laminated windscreen** • **Fire Prevention System (FPS) with fuel cut-off** • **Centre brake light**

Additional features

	Combo	Sportive
Passenger's airbag with deactivation switch	<input type="radio"/>	<input type="radio"/>
Passenger's airbag with driver and passenger's side-impact airbags	<input type="radio"/>	<input type="radio"/>
Active-safety head restraints	<input type="radio"/>	<input type="radio"/>
Electronic Stability Programme (ESP) with Hill Start Assist (HSA)	<input type="radio"/>	<input type="radio"/>

Security

Standard features • Remote control central deadlocking • Electronic engine deadlock immobiliser • Electronic theft protection for audio equipment • 'Key left in ignition' audible warning • Lockable glovebox • Lockable fuel filler cap

Additional features

	Combo	Sportive
Alarm pre-installation kit ¹	<input type="radio"/>	<input type="radio"/>
Third key	<input type="radio"/>	<input type="radio"/>
Third key with remote control	<input type="radio"/>	<input type="radio"/>

Facia, instruments and controls

Standard features • **Trip computer** – provides information on overall distance, trip distance, average and instantaneous fuel consumption, remaining range, distance and average speed since last reset • **Trip odometer** • **Rev counter** • **Electronically controlled coolant temperature gauge and fuel gauge with low fuel level warning light** • **Service-due indicator** • **12-volt accessory socket** • **Digital clock** • **Reach and rake-adjustable steering column** • **Lidded glovebox** • **Dipping rear-view mirror** (when glazed bulkhead and glazed rear doors/tailgate are specified) • **Storage compartment on driver's side facia**

Additional features

	Combo	Sportive
Cruise control	<input type="radio"/>	<input type="radio"/>
Leather-covered steering wheel	<input type="checkbox"/>	<input type="checkbox"/>
Leather-covered gear knob (manual models)	<input type="checkbox"/>	<input type="checkbox"/>

Seating

Standard features • **Cube cloth seat trim** • **Reach and rake-adjustable driver and passenger's seat**

Additional features

	Combo	Sportive
Vinyl seat trim ²	<input type="radio"/>	<input type="radio"/>
Height-adjustable driver's seat with armrest and lumbar support	<input type="radio"/>	<input checked="" type="radio"/>
Passenger's seat with under cushion storage compartment ²	<input type="radio"/>	<input type="radio"/>

Audio, communication and navigation

Features	Combo	Sportive
CD player/stereo radio • CD player • AM/FM stereo radio with 24 station presets • RDS with Traffic Programme • Four 20-watt speakers	●	●
CD/MP3 CD player/stereo radio (CD 50 multimedia) • CD/MP3 CD player • Bluetooth® connectivity for compatible mobile phones • Aux-in socket • USB connectivity • AM/FM stereo radio with 24 station presets • RDS with Traffic Programme • Steering wheel mounted audio controls • Four 20-watt speakers	□	□
Pre-installation for TomTom navigation system (excludes sat nav) ³	□	□
Flexible roof-mounted aerial	●	●



CD 50 multimedia.

Interior

Standard features • Cabin interior courtesy light operated by door switches • Four-speed air blend heater • Two coat hooks
• Door armrests • Overhead shelf (H2 models) • Door storage pockets • Twin sunvisors, front passenger's with vanity mirror
• 12v accessory socket • Vinyl floor covering in cabin area • Passenger assist handle

Additional features	Combo	Sportive
Air conditioning	○	●
Electronic Climate Control (ECC) incorporating air conditioning (mandates Winter Pack at extra cost)		○
Overhead shelf (H1 models)	□	●
Cigar lighter and removable ashtray	□	□
Soundproofed bulkhead		●

Mechanical

Standard features • Front-wheel drive • Five-speed manual gearbox (1.4i 16v/1.3CDTi) • Six-speed manual gearbox (1.6CDTi (105PS)/2.0CDTi) • Five-speed Tecshift transmission (1.6CDTi (90PS)) • Electric power-assisted steering

Additional feature	Combo	Sportive
Up-rated alternator	○	○

Exterior

Standard features • Electrically operated front windows • Body side-protection mouldings • Black door mirrors • Windscreen wipers with variable intermittent facility and flick/wipe

Additional features	Combo	Sportive
Rear parking distance sensors	○	○
Roof rails (H1 models only) ⁴	○	○
Body-colour front and rear bumpers		●
Body-colour exterior door mirrors		●
Two-coat metallic paint	○	●



Air conditioning and air recirculation.

- = Standard equipment.
- = Optional at extra cost.
- = Only available as part of an extra-cost option pack.

- 1 = Accessory alarm available at extra cost.
- 2 = Vinyl seat trim is unavailable in conjunction with height-adjustable driver's seat or passenger's seat with under cushion storage.
- 3 = Accessory sat nav available at extra cost.
- 4 = Not available with rear roof flap.



Sportive 15-inch full-diameter wheel trims.



Sportive 16-inch alloy wheels (optional).

- = Standard equipment.
- = Optional at extra cost.
- N/C = No-cost option.
- = Only available as part of an extra-cost option pack.

- 3 = Accessory sat nav available at extra cost.
- 5 = Only available when glazed rear doors or tailgate are specified.
- 6 = Only available with Load Compartment Pack.
- 7 = Only available when full-height steel bulkhead with window is specified.
- 8 = Not available with roof rails, glazed tailgate or full-size spare wheel.
- 9 = Not available with Load Compartment Pack or rear roof flap.

Load area

Standard features • Full-height steel bulkhead • Load restraint lashing eyes (six) • Illuminated load area • Unglazed asymmetric rear doors (90°/180°)

Additional features	Combo	Sportive
Full-height steel bulkhead with window ⁵	○	○
Protective ladder frame behind driver in lieu of full-height steel bulkhead	N/C ⁶	N/C
PVC load floor covering	□	●
Nearside sliding side-access door (standard on L2 models)	○	●
Offside sliding side-access door (standard on L2 models)		○
Nearside and offside sliding side-access doors (standard on L2 models)	○	
Fixed windows in nearside sliding side-access door and opposite panel/door	○	○
Glazed asymmetric rear doors with heated windows and wash/wipe facility ⁷	○	○
Glazed tailgate with heated window and wash/wipe facility (H1 models) ⁷	○	○
Removable load area courtesy light	□	
Rear roof flap (L1 H1 models only) ^{6,8}	○	○
Internal ladder storage bars ⁹	○	○
12-volt accessory socket in load area	□	

Wheels and tyres

Features	Combo	Sportive
15-inch steel wheels with centre covers and 185/65 R 15 tyres (2000 models)	●	
16-inch steel wheels with centre covers and 195/60 R 16 tyres (2300 models)	●	
15-inch steel wheels with full-diameter wheel trims and 185/65 R 15 tyres (1.3CDTi and 1.6CDTi 2000 models)		●
16-inch steel wheels with full-diameter wheel trims and 195/60 R 16 tyres (2.0CDTi and 2300 models)		●
16-inch alloy wheels with 195/60 R 16 tyres		○
Winter tyres – Goodyear Ultragrip-7 185/65 R 15 (2000 models) or 185/65 R 16 (2300 models)	○	
Tyre inflation kit	●	●
Full-size spare wheel (in lieu of tyre inflation kit)	N/C	N/C

Option packs

Additional features	Combo	Sportive
Driver Pack • CD/MP3 CD player/stereo radio/Bluetooth® connectivity for compatible mobile phones/aux-in socket/USB connectivity/RDS with Traffic Programme/steering wheel mounted audio controls • Leather-covered steering wheel • Leather-covered gear knob (manual models) • Pre-installation for TomTom navigation system (excludes sat nav) ³	○	○
Load Compartment Pack • Overhead shelf • PVC load floor covering • 12-volt accessory socket in load area • Removable load area courtesy light	○	
Winter Pack • Headlight washers • Front fog lights • Exterior temperature sensor • Electrically adjustable door mirrors		○
Smoker Pack • Cigar lighter • Removable ashtray	○	○

Power and torque curves

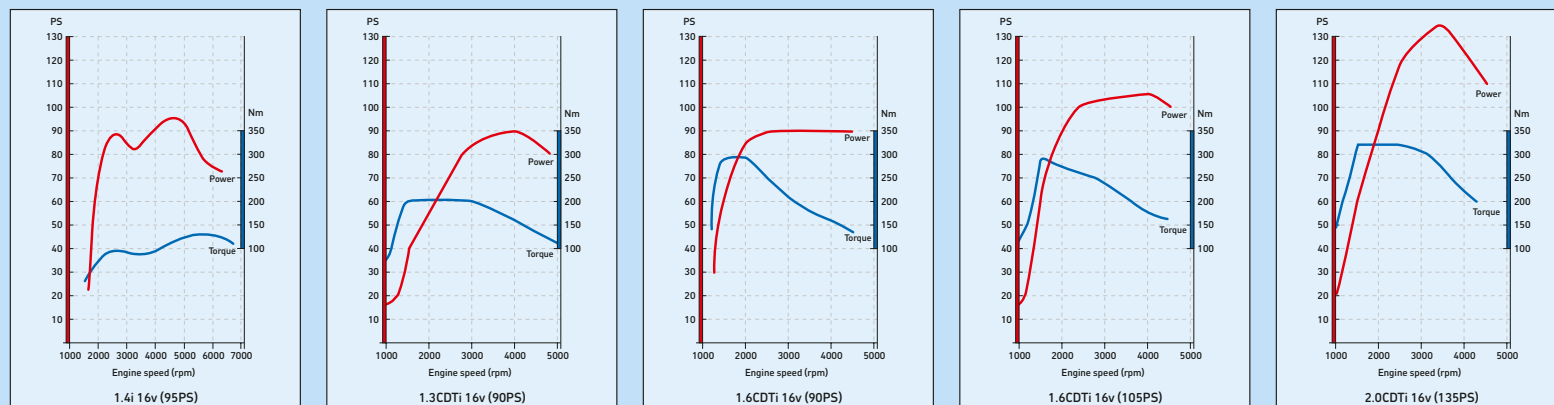

Engines

	1.4i 16v (95PS) with Start/Stop	1.3CDTi 16v (90PS) with or without Start/Stop	1.6CDTi 16v (90PS) with Start/Stop	1.6CDTi 16v (105PS) with Start/Stop	2.0CDTi 16v (135PS) with Start/Stop
Fuel type	Petrol	Diesel	Diesel	Diesel	Diesel
Capacity	1368cc	1248cc	1598cc	1598cc	1956cc
Maximum power	95PS (70kW) @ 6000rpm	90PS (66kW) @ 4000rpm	90PS (66kW) @ 4000rpm	105PS (77kW) @ 4000rpm	135PS (99kW) @ 3500rpm
Maximum torque	127Nm (94 lb.ft.) @ 4500rpm	200Nm (148 lb.ft.) @ 1500rpm	290Nm (214 lb.ft.) @ 1500rpm	290Nm (214 lb.ft.) @ 1500rpm	320Nm (236 lb.ft.) @ 1500rpm
Configuration	4 cylinders, 4 valves per cylinder, double overhead camshafts				
Emission compliance	Euro 5				
Fuel/induction system	Multi-point sequential fuel injection	Turbocharger with intercooler, Common rail fuel injection			
Service intervals	18,000 miles or one-year (whichever occurs sooner)	21,000 miles or one-year (whichever occurs sooner)			

Transmission ratios

	Gear ratios (mph/1000rpm)						Reverse	Final drive ratio
	1	2	3	4	5	6		
2000 1.4i 16v (95PS)	4.10:1 (3.5)	2.16:1 (6.7)	1.34:1 (10.7)	0.97:1 (14.8)	0.83:1 (17.3)	-	3.81:1	4.92:1
2000 1.3CDTi 16v (90PS)/1.6CDTi 16v (90PS)	4.27:1 (4.2)	2.24:1 (8.0)	1.44:1 (12.5)	1.03:1 (17.5)	0.79:1 (22.8)	-	3.91:1	3.93:1
2000 1.6CDTi 16v (105PS)	4.15:1 (4.4)	2.12:1 (8.7)	1.36:1 (13.6)	0.98:1 (18.8)	0.76:1 (24.3)	0.62:1 (29.8)	4.00:1	3.83:1
2000 2.0CDTi 16v (135PS)	4.15:1 (4.6)	2.12:1 (9.0)	1.36:1 (14.0)	0.98:1 (19.4)	0.76:1 (25.0)	0.62:1 (30.6)	4.00:1	3.83:1
2300 1.4i 16v (95PS)	4.10:1 (3.6)	2.16:1 (6.8)	1.34:1 (11.0)	0.97:1 (15.2)	0.83:1 (17.8)	-	3.81:1	4.92:1
2300 1.3CDTi 16v (90PS)/1.6CDTi 16v (90PS)	4.27:1 (4.3)	2.24:1 (8.3)	1.44:1 (12.9)	1.03:1 (18.0)	0.79:1 (23.4)	-	3.91:1	3.93:1
2300 1.6CDTi 16v (105PS)/2.0CDTi (135PS)	4.15:1 (4.6)	2.12:1 (9.0)	1.36:1 (14.0)	0.98:1 (19.4)	0.76:1 (25.0)	0.62:1 (30.6)	4.00:1	3.83:1



Five-speed Tecshift transmission.

Vauxhall Assistance and warranties*

Every New Combo comes with:

- A three-year vehicle warranty consisting of a one year/unlimited mileage manufacturer's warranty and a second and third-year manufacturer's warranty with a 60,000 miles limitation
- Vauxhall Assistance for 12 months from first registration
- Six years' body panel anti-perforation warranty

* = Warranty is only available on vehicles sourced from General Motors UK Limited. Terms and conditions apply – please see your Vauxhall retailer for details.

Insurance groups

Range from 2ET2 to 4ET2 dependent on model specified.

Transmissions

- Front-wheel drive
- 1.4i 16v/1.3CDTi 16v: Five-speed manual
- 1.6CDTi 16v (105PS)/2.0CDTi 16v: Six-speed manual
- 1.6CDTi 16v (90PS): Five-speed Tecshift

Steering

- Hydraulic power-assisted rack and pinion system
- Energy-absorbing steering column
- Kerb-to-kerb turning circle:
 - L1: 11.2m (36.7ft)
 - L2: 12.5m (41.0ft)

Suspension

Front:

- Independent MacPherson struts with coil springs, gas-pressure dampers and anti-roll bar

Rear:

- Bi-link with coil springs, gas-pressure dampers and anti-roll bar

Brakes

- Anti-lock Braking System (ABS) with Electronic Brakeforce Distribution (EBD)

Front ventilated disc brakes:

- 1.3CDTi 16v/1.6CDTi 16v (90/105PS) 2000 models: 284mm diameter
- 1.4i 16v/2.0CDTi 16v and 2300 models: 305mm diameter

Rear self-adjusting drum brakes:

- 1.3CDTi 16v/1.6CDTi 16v (90/105PS): 228mm diameter
- 1.4i 16v/2.0CDTi 16v: 254mm diameter

Electrics

Alternator:

- 1.4i 16v/1.3CDTi 16v: 105A
- 1.6CDTi 16v (90/105PS)/2.0CDTi 16v: 100A
- Models with air conditioning: 120A

Maintenance-free battery:

- 1.4i 16v/1.3CDTi 16v: 63Ah
- 1.6CDTi 16v (90/105PS)/2.0CDTi 16v: 72Ah

Body

- Six-year body panel anti-perforation warranty
- Galvanised body panels
- Anti stone-chip mastic coating on sills
- Flush-fitted windscreen and rear door glass (when specified)
- Detachable front towing eye
- Rear towing eye

Fuel tank capacity

60 litres (13.2 gallons)

Weights and towing data

	UK Plated weights and kerbweights kg							Payload kg	Towing weights Trailer with brakes (without brakes) kg	Plated Gross Combination Weights (GCW) kg
	Front axle		Rear axle		Total GVW	Kerb				
	Plated	Kerb	Plated	Kerb						
L1 H1 panel van										
2000 1.4i 16v (95PS) S/S	1090	772	1140	468	1990	1240	750	1000 (500)	2990	
2000 1.3CDTi 16v (90PS)	1090	790	1140	480	2020	1270	750	1000 (500)	3020	
2000 1.3CDTi 16v (90PS) ecoFLEX S/S	1090	790	1140	480	2020	1270	750	1000 (500)	3020	
2000 1.6CDTi 16v (90PS) S/S Tecshift	1090	835	1140	475	2060	1310	750	1300 (500)	3360	
2000 1.6CDTi 16v (105PS) S/S	1090	835	1140	475	2060	1310	750	1300 (500)	3360	
2300 1.3CDTi 16v (90PS)	1090	785	1450	505	2290	1290	1000	1000 (500)	3290	
2300 1.3CDTi 16v (90PS) ecoFLEX S/S	1090	785	1450	505	2290	1290	1000	1000 (500)	3290	
2300 1.6CDTi 16v (90PS) S/S Tecshift	1090	830	1450	500	2330	1330	1000	1300 (500)	3500	
2300 1.6CDTi 16v (105PS) S/S	1090	830	1450	500	2330	1330	1000	1300 (500)	3500	
2000 1.3CDTi 16v (90PS) Sportive	1090	813	1140	502	2020	1315	705	1000 (500)	3020	
2000 1.3CDTi 16v (90PS) ecoFLEX S/S Sportive	1090	813	1140	502	2020	1315	705	1000 (500)	3020	
2000 1.6CDTi 16v (105PS) S/S Sportive	1090	858	1140	497	2060	1355	705	1300 (500)	3360	
2000 2.0CDTi 16v (135PS) S/S Sportive	1120	893	1140	502	2100	1395	705	1500 (500)	3500	
2300 1.3CDTi 16v (90PS) Sportive	1090	808	1450	527	2290	1335	955	1000 (500)	3290	
2300 1.3CDTi 16v (90PS) ecoFLEX S/S Sportive	1090	808	1450	527	2290	1335	955	1000 (500)	3290	
2300 1.6CDTi 16v (105PS) S/S Sportive	1090	853	1450	522	2330	1375	955	1300 (500)	3500	
2300 2.0CDTi 16v (135PS) S/S Sportive	1120	888	1450	527	2370	1415	955	1500 (500)	3500	
L1 H2 panel van										
2000 1.6CDTi 16v (90PS) S/S Tecshift	1090	845	1140	485	2080	1330	750	1300 (500)	3380	
2000 1.6CDTi 16v (105PS) S/S	1090	845	1140	485	2080	1330	750	1300 (500)	3380	
2300 1.6CDTi 16v (90PS) S/S Tecshift	1090	840	1450	510	2350	1350	1000	1300 (500)	3500	
2300 1.6CDTi 16v (105PS) S/S	1090	840	1450	510	2350	1350	1000	1300 (500)	3500	
2000 1.6CDTi 16v (105PS) S/S Sportive	1090	865	1140	505	2080	1370	710	1300 (500)	3380	
2300 1.6CDTi 16v (105PS) S/S Sportive	1090	860	1450	530	2350	1390	960	1300 (500)	3500	
L2 H1 panel van										
2300 1.4i 16v (95PS) S/S	1090	786	1450	514	2200	1300	900	1000 (500)	3200	
2300 1.3CDTi 16v (90PS)	1090	805	1450	525	2330	1330	1000	1000 (500)	3330	
2300 1.3CDTi 16v (90PS) ecoFLEX S/S	1090	805	1450	525	2330	1330	1000	1000 (500)	3330	
2300 1.6CDTi 16v (90PS) S/S Tecshift	1090	850	1450	520	2370	1370	1000	1300 (500)	3500	
2300 1.6CDTi 16v (105PS) S/S	1090	850	1450	520	2370	1370	1000	1300 (500)	3500	
2300 1.3CDTi 16v (90PS) Sportive	1090	825	1450	535	2330	1360	970	1000 (500)	3330	
2300 1.3CDTi 16v (90PS) ecoFLEX S/S Sportive	1090	825	1450	535	2330	1360	970	1000 (500)	3330	
2300 1.6CDTi 16v (105PS) S/S Sportive	1090	870	1450	530	2370	1400	970	1300 (500)	3500	

Note: Kerbweights for standard vehicles include coolant, oil, 90% full fuel tank and spare wheel. They will vary according to the vehicle specification (including options and accessories) with a corresponding variation in payload. Payload figures do not allow for the weight of the driver, or any passengers, which should therefore be deducted from the figures shown. Gross plated weights (including axle weights) quoted on the vehicle plate must never be exceeded. Roof load on H1 models should not exceed 100kg including the weight of the roof rack/carrier when Vauxhall approved carrier system used. H2 models are not permitted to carry roof loads.

L1 H1

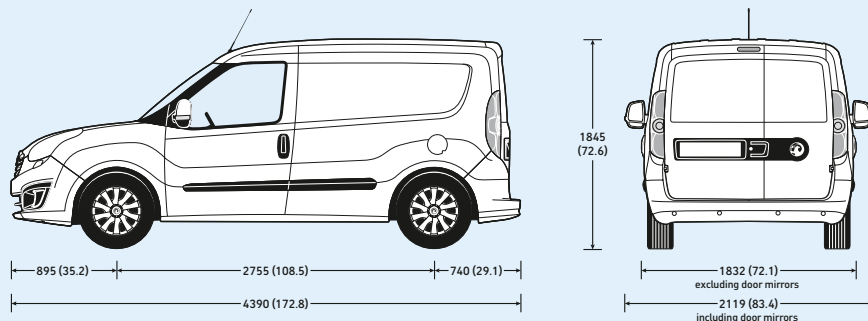

L1 H2

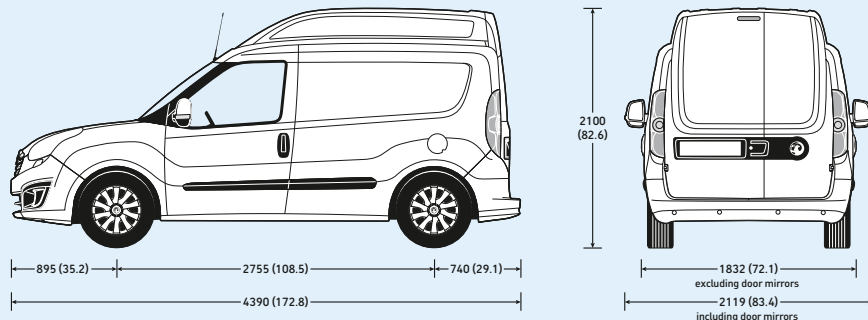

L2 H1

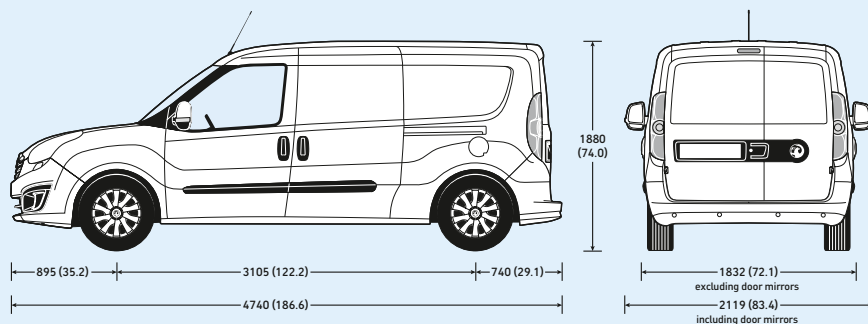

Measurements are shown in millimetres (inches). All heights are shown unladen and exclude roof rails.

Interior dimensions mm (inches)

Loadspace	L1	L2
Maximum length	1820 (71.7)	2170 (85.4)
Maximum width	1714 (67.5)	1714 (67.5)
Maximum height – H1	1305 (51.4)	1305 (51.4)
Maximum height – H2	1550 (61.0)	–
Width between wheel arches	1230 (48.4)	1230 (48.4)
Side door(s)		
Aperture height	1175 (46.2)	1175 (46.2)
Aperture width	700 (27.5)	700 (27.5)
Rear doors		
Aperture height – H1	1250 (49.2)	1250 (49.2)
Aperture height – H2	1455 (57.2)	–
Aperture width	1231 (48.5)	1231 (48.5)
Loading height	545 (21.4)	545 (21.4)
Loadspace volumes cu.m (cu.ft.)		
H1	3.4 (121)	4.2 (148)
H2	4.0 (141)	–

Fuel economy and emissions (Combo and Sportive models)

	Fuel economy mpg (litres/100km)			CO ₂ emissions (g/km)
	Urban driving	Extra-urban driving	Combined figure	
L1 H1				
2000 1.4i 16v (95PS) S/S	30.7 (9.2)	49.6 (5.7)	40.3 (7.0)	163
2000 1.3CDTi 16v (90PS)	43.5 (6.5)	67.3 (4.2)	56.5 (5.0)	133
2000 1.3CDTi 16v (90PS) ecoFLEX S/S	47.9 (5.9)	67.3 (4.2)	58.9 (4.8)	126
2000 1.6CDTi 16v (90PS) S/S Tecshift	51.4 (5.5)	61.4 (4.6)	57.6 (4.9)	130
2000 1.6CDTi 16v (105PS) S/S	46.3 (6.1)	61.4 (4.6)	54.3 (5.2)	136
2000 2.0CDTi 16v (135PS) S/S	43.5 (6.5)	55.4 (5.1)	50.4 (5.6)	148
2300 1.3CDTi 16v (90PS)	43.5 (6.5)	67.3 (4.2)	56.5 (5.0)	133
2300 1.3CDTi 16v (90PS) ecoFLEX S/S	47.9 (5.9)	67.3 (4.2)	58.9 (4.8)	126
2300 1.6CDTi 16v (90PS) S/S Tecshift	50.4 (5.6)	60.1 (4.7)	56.5 (5.0)	133
2300 1.6CDTi 16v (105PS) S/S	45.6 (6.2)	61.4 (4.6)	54.3 (5.2)	137
2300 2.0CDTi 16v (135PS) S/S	43.5 (6.5)	55.4 (5.1)	50.4 (5.6)	148

	Fuel economy mpg (litres/100km)			CO ₂ emissions (g/km)
	Urban driving	Extra-urban driving	Combined figure	
L1 H2				
2000 1.6CDTi 16v (90PS) S/S Tecshift	50.4 (5.6)	54.3 (5.2)	53.3 (5.3)	140
2000 1.6CDTi 16v (105PS) S/S	44.8 (6.3)	55.4 (5.1)	51.4 (5.5)	146
2300 1.6CDTi 16v (90PS) S/S Tecshift	50.4 (5.6)	54.3 (5.2)	53.3 (5.3)	140
2300 1.6CDTi 16v (105PS) S/S	44.8 (6.3)	55.4 (5.1)	51.4 (5.5)	146
L2 H1				
2300 1.4i 16v (95PS) S/S	29.1 (9.7)	47.9 (5.9)	38.7 (7.3)	168
2300 1.3CDTi 16v (90PS)	42.8 (6.6)	65.7 (4.3)	55.4 (5.1)	136
2300 1.3CDTi 16v (90PS) ecoFLEX S/S	47.1 (6.0)	65.7 (4.3)	57.6 (4.9)	129
2300 1.6CDTi 16v (90PS) S/S Tecshift	50.4 (5.6)	60.1 (4.7)	56.5 (5.0)	133
2300 1.6CDTi 16v (105PS) S/S	45.6 (6.2)	61.4 (4.6)	54.3 (5.2)	137

S/S = Start/Stop.

Fuel consumption and CO₂ emission data complies with the relevant EU testing regulations used by vehicle manufacturers to enable comparisons between different models. **Important:** Please note fuel consumption can be affected by many factors including driving style, road and traffic conditions, vehicle mileage and standard of maintenance. In addition these results relate to the particular vehicle tested, inevitably there will be differences between individual vehicles of the same model.

Glossary of terms

Plated weight

The maximum weight to which a vehicle or an axle may be loaded, determined either by the design of the components or by legislation. All commercial vehicles must carry a manufacturer's 'plate' showing the vehicle and axle gross 'plated weights'. It is an offence to drive a vehicle in a condition where any of these weights are exceeded.

Kerbweight

The weight of the complete vehicle in standard form, excluding payload and driver but including coolant, oil, 90% full fuel tank and spare wheel where fitted. Kerbweights quoted in Vauxhall brochures are subject to manufacturing tolerances

and to the fitment of optional equipment and accessories. Where load capacity is critical the actual kerbweight should be obtained by weighing the vehicle on a calibrated public weighbridge.

Gross Vehicle Weight (GVW)

The total permissible weight of a vehicle including payload and passengers, as shown on the manufacturer's plate.

Gross Combination Weight (GCW)

The maximum permissible weight of a vehicle, including payload and passengers, combined with the total weight of any trailer it is towing. The maximum GCW weight limit is quoted on the vehicle plate and must not be exceeded.

Payload

The total permissible weight that can be carried without exceeding the vehicle's plated weight. This can be obtained by deducting the kerbweight from the plated Gross Vehicle Weight (GVW). Please note: the payload figure does not allow for the weight of the driver or any passengers which should therefore be deducted from the figures shown and are also subject to correct weight distribution.

Maximum towing weight

The maximum weight of any trailer and its load which may be towed within the limit of the vehicle's plated Gross Combination Weight (GCW). It is based on the ability of

the vehicle – at full GCW – to restart on a 12% gradient, which is approximately 1 in 8.3, at sea level. At altitudes above 1500 metres, the engine output may drop with a corresponding reduction in towing capability. It is the operator's responsibility to ensure that the trailer noseweight does not cause the rear axle plated weight of the towing vehicle to be exceeded.

Always fit Vauxhall towing attachments and accessories available from your Vauxhall Commercial Vehicle retailer. They are designed specifically for Vauxhall models and carry a 12-month warranty.

Trust Vauxhall

Protecting the environment

Vauxhall's commitment to the environment is demonstrated by our products' many environmental awards, won both through the use of more recycled materials and by becoming cleaner and more efficient. For information on Vauxhall's efforts to achieve an environmentally sustainable future, see www.vauxhall.co.uk/recycling

Fleet Customer Services

Our dedicated support services for fleet managers includes factory demonstrators and information on whole life costs, company car and van taxation and finance. For further information please call **0870 010 0651**.

Vauxhall Extended Warranty

For complete peace of mind Vauxhall offers an extended warranty that can be purchased on an annual basis following the expiry of the original new vehicle warranty. It covers most mechanical and electrical components. Terms and conditions apply. For further details please contact your local Vauxhall Commercial Vehicle retailer.



When you have finished with this brochure please recycle it

Business Lease

Business Lease, from GMAC, offers the versatility of a purchase-based finance plan, while making the most efficient use of tax and cash-flow benefits for VAT-registered business users. It's available for all Vauxhall Commercial Vehicles up to 12 months old and offers highly flexible term lengths, variable deposits and a choice of payment profiles. Ask your retailer for full details.

Business First

Available to business users only, Business First enables you to drive a new vehicle without a large, initial financial outlay. You pay to use the vehicle, not to own it. The vehicle is provided over a predetermined period, and when that period comes to an end the vehicle is returned. Ask your retailer for full details.

Servicing and maintenance

The best way to maximise the performance and reliability of your Vauxhall is to have all routine servicing and maintenance carried out at a Vauxhall Commercial Vehicle retailer. Nationwide there are over 250 light commercial vehicle retailers and a further 195 heavy commercial vehicle retailers.

In the event of an accident...

Vauxhall Accident Support helps keep you mobile following an accident. Benefits include scene-of-accident advice, message service, assistance with claims and vehicle recovery. For further details call **0800 010 304**.

Premier Service Centres

Our Premier Service Centres feature a guaranteed same day repair service (provided the parts are in stock) and an appointment-free service for diagnosis and repairs taking less than 90 minutes. All repairs are carried out within 24 hours of the diagnosis.

For more information...

For a brochure on any Vauxhall model (up to a maximum of three per caller) or location of your nearest retailer, call **0845 600 1500**.

Alternatively, details can be found on our website at: www.vauxhall.co.uk/vans

Proud Sponsor of Home Nations Football



Every effort has been made to ensure that the contents of this publication were accurate and up-to-date at the time of going to press (July 2012). Vauxhall vehicles are equipped with components manufactured by various General Motors operating units and outside suppliers. The Company reserves the right to alter specifications and withdraw products from sale without notice. Any such alterations will be notified to Vauxhall retailers at the earliest opportunity, please consult your local retailer for the latest information. The specifications detailed within this brochure are not necessarily applicable to alternative models such as Special Editions. Details of any such models will be contained in specific literature or found on the Vauxhall website. Please note that Vauxhall retailers are not the agents of General Motors UK Limited and are not authorised to bind the Company by any specific or implied undertaking or representation. It is advisable to ensure that your motor insurance policy provides adequate cover for additional fitted options and accessories. Please note accessories shown are for illustrative purposes only. As part of Vauxhall's policy of environmental care, this brochure is printed on paper manufactured using Elemental Chlorine Free pulps from specially farmed, sustainable timber resources. All rights reserved. No part of this publication may be reproduced in any form or by any means, without the prior written permission of General Motors UK Limited.

V1 ©2012 General Motors UK Limited Published July 2012 General Motors UK Limited, Luton LU1 3YT

COMMERCIAL VEHICLES
The Wheels of Business



VAUXHALL