

Corsavan

The small van that gives you more

2010 Models Edition 1



The Wheels of Business – Helping you deliver.

Whatever your business, Vauxhall Commercial Vehicles can help you deliver. With five different models, we offer a massive choice of over 200 variants including vans, tippers and minibuses. We're also committed to keeping your business moving. Reliable, fuel-efficient vehicles supported by a dedicated network of over 300 specialist retailers with all the expert support and back-up you need to minimise service downtime.

Since 2007, our British production facilities at Ellesmere Port and Luton have built over 260,000 commercial vehicles – that's more than any other UK manufacturer. We've also won over 25 industry awards since 2001 – major awards, presented by the toughest judges in the business.

So that's Vauxhall Commercial Vehicles: huge range, great product and the expert support of a nationwide network of retailers. But don't just take our word for it...

Some of the vehicles shown in this brochure include options and accessories available at extra cost. And not all of the features described are available on every model. So please check the equipment and technical data section for further details. From time to time, we also offer alternative models such as Special Editions which are featured in separate literature or can be found on the Vauxhall website: www.vauxhall.co.uk/vans



Movano



Vivaro



Combo



Astravan



Corsavan

Movano...

'We currently operate a fleet of 2400 GM models; within these, roughly 500 are Movanos – predominantly 2.5CDTi 16v (100PS) models. These vehicles are real workhorses'

Stewart Duff, Fleet Commercial Manager, Scottish Power



Vivaro...

'The Vivaro is big enough for what we ask of it, economical to run and gets the job done. I can't really put it any better than that!'

Paul Pogson, Managing Director, Catercover Service



Combo...

'The 1.3CDTi 16v common rail turbo diesel unit has acquitted itself well over time and our drivers seem to like its flexibility and its overall performance in day-to-day use.'

Paul Gatti, Head of Commercial Fleet, Royal Mail



Astravan...

'We particularly like the 1.3CDTi 16v engine – it's been a big success. It's good to drive... and low CO₂ emissions are a big consideration to us'

Tony Carrea, Fleet Manager, SDC

Corsavan...

'The vans are very well-equipped and competitive on key areas like running costs and maintenance'

Paul Harris, Fleet Manager, Cams Fire and Security



Corsavan 4

Loadspace 6

Dynamics and efficiency 8

Models 10

Options and accessories 14

Customer advocates 16

Equipment and technical data 18

Colour availability 22



Sportive model illustrated.

THE SMALL VAN THAT GIVES YOU MORE

With its sporty good looks, Corsavan makes a clear style statement for any image-conscious business. Small enough for congested city streets, yet big enough to eat up the miles on the open road, it matches a dynamic chassis with a light, spacious cabin and high levels of safety and security. And the load area is easy to access with purpose-built load protection and a class-leading 550kg payload capacity.

Corsavan's stylish shape is noticeably longer, taller and wider than many competitors, meaning more space for the driver and passenger. The full-length flat floor makes it practical and easier to load. And, at 550kg, Corsavan payload capacity surpasses each of its would-be rivals.

Few vans can match Corsavan's low running costs. Both the 1.3CDTi 16v diesel engines and the 1.2i 16v petrol engine are economical and insurance group ratings are low (1E T2). Service intervals are a long 20,000 miles/one year on all models and the warranty stretches to three years/60,000 miles.

The Corsavan cabin is built for long-term driver comfort. The seats provide outstanding levels of support. The fascia is both stylish and ergonomically efficient, with a stereo radio/CD player fitted as standard. There is also plenty of useful in-cab storage for your paperwork, drinks and all those other essentials for a busy working day.

With a choice of two models, Corsavan and the Corsavan Sportive – the latter complete with body-colour detailing, 15-inch alloy wheels, a 1.3CDTi 16v (90PS) common rail turbo diesel engine and six-speed gearbox – it's clear to see it's the small van that gives you more.

Sportive model illustrated (right) features accessory Smoker Pack (cigarette lighter and ashtray).



Corsavan



Max. payload
550kg



3-year/60,000 mile
warranty



Insurance Group
1E T2

WHAT VAN? ONLINE SAID...

'... it comfortably outclasses Bipper and similar products so far as driveability is concerned.'

JANUARY 2009

Corsavan takes its load carrying duties very seriously indeed, with strong attention to detail in the areas that really matter. A tall, wide tailgate aperture makes it easy to load. The long, high load area has superb load and occupant protection features. Most of all, it carries an impressive 550kg maximum payload – a figure that puts all its major competitors in the shade.

EASY LOADABILITY

The Corsavan has never been easier to load. The tall tailgate aperture allows larger items to be loaded. The tailgate itself lifts high (for good headroom) and extends down into the bumper making for a low loading height.

LOAD PROTECTION

A sturdy steel floor and half-height steel bulkhead, tough sidewall half-height panelling and load restraint lashing eyes are all standard. An upper load restraint mesh, fitted rubber floor mat and four-piece load compartment cover are optional for even more load protection.



◀ Four-piece load compartment cover optional at extra cost.

LOADSPACE DIMENSIONS*

	mm	inches
Maximum load floor length	1257	49.5
Maximum load area height	924	36.4
Maximum load area width	1264	49.8
Width between wheel arches	969	38.1
Load sill height (unladen)	691	27.2
Maximum tailgate aperture height	650	25.6
Maximum tailgate aperture width	980	38.6

LOADSPACE VOLUME

	cu.m	cu.ft
Maximum loadspace volume (VDA method)	0.92	32.5

*Please refer to pages 21–23 of the technical data section for more detailed loadspace, weight and towing data.

◀ Corsavan's high-lift tailgate opens to reveal a practical 0.92 cu.m (32.5 cu.ft) loadspace. For additional load and occupant protection, a steel upper load restraint mesh and rubber floor mat (both illustrated) are optional at extra cost.



Max. load floor length



Max. payload 550kg



LOADSPACE

- | 550kg maximum payload
- | Steel load area floor
- | Half-height steel bulkhead
- | Sidewall half-height panelling
- | Load restraint lashing eyes
- | Upper load restraint mesh (optional)
- | Fitted rubber floor mat (optional)
- | Four-piece load compartment cover (optional)



DYNAMICS AND EFFICIENCY

- | Choice of engines: 1.2i 16v (70PS/115Nm) petrol, 1.3CDTi 16v (75PS/170Nm) ecoFLEX and 1.3CDTi 16v (90PS/200Nm)* diesels
 - | Five-speed manual gearbox** | Six-speed manual gearbox* | Anti-lock Braking System (ABS) with Electronic Brakeforce Distribution (EBD)
 - | Electric speed-sensitive power-assisted steering | Dynamic Safety Suspension (DSA) | Three-year manufacturer's warranty consisting of a one-year/unlimited mileage warranty plus a second and third year warranty up to 60,000 miles
- *Sportive models only. **Excluding Sportive models.

Driving comfort, affordability and safety are major considerations for any busy working van driver. So Corsavan's car-like ride and handling help ensure a comfortable and relaxing day at the wheel – especially now with modifications to the spring, damper and anti-roll bar settings providing even more driving comfort. Both engine choices – common rail diesel and multi-valve petrol, are designed to save you money. And anti-lock Braking System (ABS) with Electronic Brakeforce Distribution (EBD) is standard, as is speed-sensitive power-assisted steering, making Corsavan especially easy to manoeuvre and park.

WHAT VAN? ONLINE SAID...

'As for keeping your fuel bills down, how does 56mpg grab you?'

JANUARY 2009 1.3CDTi 16v (75PS)

Dynamic Safety Suspension (DSA).

When any vehicle brakes on surfaces with differing levels of grip (eg. gravel or mud versus dry tarmac), there is always the potential for loss of control. Corsavan's DSA suspension helps correct this tendency, making the van safer under 'break away' conditions.

▶ Anti-lock Braking System (ABS).

The latest ABS system with Electronic Brakeforce Distribution (EBD) and Emergency Brake Assist (EBA) can reduce emergency stopping distances even further, particularly on slippery roads and help drivers retain steering control.

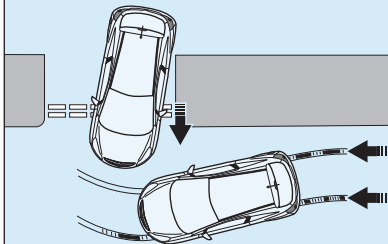

Corsavan ecoFLEX models.

The Corsavan ecoFLEX models have amongst the lowest vehicle CO₂ emissions in the UK. Not only is the 1.3CDTi 16v (75PS) turbo diesel engine fuel efficient, its advanced common rail technology also makes it one of the smoothest and most flexible units in its class.

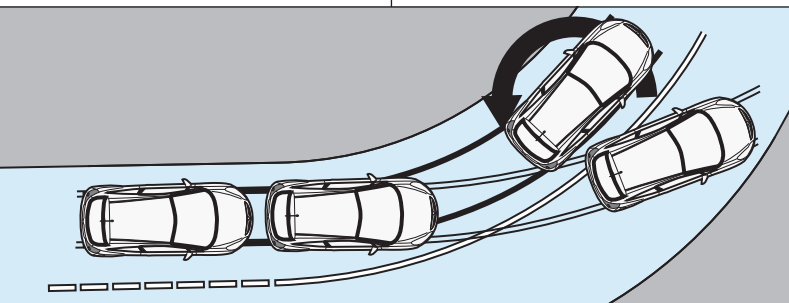

▶ 1.3CDTi 16v common rail diesel.

Base models feature our award-winning 1.3CDTi 16v (75PS) ecoFLEX engine matched to a five-speed gearbox. Sportive models take the 90PS version matched to a six-speed gearbox. Both versions deliver outstanding performance combined with excellent fuel economy.



▶ **ESP-plus and TC.** The optional Electronic Stability Programme-plus (ESP-plus) with Enhanced Understeering Control (EUC) works in conjunction with the vehicle's Traction Control (TC) system to help you maintain control during adverse or emergency conditions. Sensing when the vehicle is about to slide on a bend, ESP-plus gently applies corrective braking to the appropriate wheel or wheels, correcting the slide and helping you regain control more rapidly. Traction control also stops wheelspin during acceleration.



▶ **1.2i 16v Twinport.** The 70PS (115Nm) multi-valve petrol engine uses advanced Twinport technology for increased performance and fuel economy and meets Euro 5 emission standards. This unit is backed by a five-speed manual gearbox.



CORSAVAN

Known simply as Corsavan, the base model provides a well-equipped and cost-efficient introduction to the model line-up. Drivers can choose between two highly responsive yet economical engines: 75PS 1.3CDTi 16v ecoFLEX common rail turbo diesel and 70PS 1.2i 16v Twinport petrol.

Standard features include:

- | Punch Charcoal cloth seat trim
- | Driver's airbag
- | Pyrotechnic body-lock seatbelt pretensioners
- | Anti-lock braking system
- | Emergency brake assist
- | Electronic brakeforce distribution
- | Electronic engine deadlock immobiliser
- | Remote control central locking with security deadlocks
- | Speed-sensitive electric power-assisted steering
- | Five-speed manual gearbox
- | Satin stone-effect centre console
- | CD player/stereo radio (CD 30)
- | Body-coloured electrically adjustable door mirrors
- | Passenger's underseat storage tray
- | Half-height steel bulkhead
- | Steel load area floor
- | Load restraint lashing eyes



 Passenger's underseat storage tray.

In-cab stowage features include a passenger's underseat storage tray and a document pocket in the driver's sunvisor (not illustrated). Both door pockets include a drinks holder and space for bottles up to 1.5 litres; the centre console features two more drinks holders and coin holders.



 Body-coloured electrically adjustable door mirrors are standard, whilst electrically operated front windows are optional at extra cost.



Engine availability and insurance groups (ABI)

1.2i 16v	1E
1.3CDTi 16v (75PS) ecoFLEX	1E

Model illustrated (left) features optional electric windows and accessory Smoker Pack (cigarette lighter and ashtray).

SPORTIVE

With a host of exterior enhancements that include two-coat metallic paint, body-colour detailing, dark-style headlights and 15-inch alloy wheels – and power provided by a more potent 90PS 1.3CDTi 16v turbo diesel engine – Sportive is an exciting addition to the Corsavan line-up.

Additional features over and above base model include:

- | Sports-style seats with Twist trim
- | Driver's seat height adjuster
- | Reach and rake adjustable steering
- | Air conditioning
- | Electrically operated windows
- | Matt chrome-effect centre console
- | Sports instruments
- | Six-speed manual gearbox
- | Electrically adjustable/heated door mirrors
- | Body-coloured door handles
- | Dark-style headlights and tail lights
- | Front fog lights
- | 15-inch alloy wheels
- | Sportive badge
- | Sports chrome exhaust tailpipe
- | Two-coat metallic paint
- | Dark-tinted rear window



▲ Six-speed manual gearbox.

Inside, too, Corsavan Sportive adds fresh appeal and driving flair that's bound to excite any small van user. With additional design cues and extra features that include reach and rake adjustable steering, it's perfect for the business that's going places in style.

▼ Reach and rake adjustable steering.



Engine availability and insurance groups (ABI)

1.3CDTi 16v (90PS)	1E
--------------------	----

Model illustrated (left) features accessory Smoker Pack (cigarette lighter and ashtray).



Corsavan Sportive

OPTIONS AND ACCESSORIES

Vauxhall options and accessories are all about choice – selecting your Corsavan then personalising it to suit the way you work. There's a choice of factory-fitted options and a huge range of retailer-fit accessories. You can also choose styling products from the VXR range as well as auto design specialist Irmischer International. For further information please ask your Vauxhall Commercial Vehicle retailer.

INDIVIDUAL OPTIONS INCLUDE:

- > Satellite navigation/CD player with MP3 format/stereo radio (CD 60)
- > ESP-plus
- > Passenger's airbag
- > Air conditioning*
- > Electric windows*
- > Heated door mirrors*
- > Front fog lights*
- > Rear parking distance sensors
- > Load area rubber floor mat
- > Four-piece load compartment cover
- > Upper load restraint mesh



OPTION PACK

Corsavan Plus Pack*

- > Driver's seat height adjuster **1**
- > Steering column adjustable for reach and rake

**Standard on Sportive models.*



  **Load area options.** Load area safety and security can be further enhanced with a range of extra-cost options. The steel upper load restraint mesh and fitted rubber floor mat provide added protection from shifting loads, while the four-piece load compartment cover hides the load from prying eyes.



 **Rear parking distance sensors.** This factory-fitted option provides an audible warning when an object is detected within a set range behind the vehicle.



ACCESSORIES

Vauxhall accessories are the right choice for your Corsavan. Listed below is just a small sample of the range available. For a full list, please refer to the Vauxhall Commercial Vehicle Accessories brochure.

- > Headlight protectors
- > Mudflaps
- > Steering wheel security bar
- > Anti-slip mat (915mm x 915mm)
- > MetaSystem alarm
- > Safety Pack (warning triangle, first aid kit and hi-visibility vest)
- > Smoker Pack

irmscher

Developed in conjunction with auto design specialists Irmischer International, a range of styling accessories are available to enhance and help personalise your Corsavan:

- > Interior styling
- > Exterior body styling
- > Styling pack
- > Sports silencer
- > Alloy wheels

▼ **Irmischer rear hood spoiler.**

▲ **Corsavan VXR Styling Pack.** Boost your style with a front lower spoiler, side sills, rear roof spoiler and rear lower skirt.



◀ **Rubber floor mats (pair).** Rubber floor mats protect your interior from everyday wear and tear. All come with secure fixings and an anti-slip underside.



◀ **Base carrier.** The Vauxhall roof rack system begins with this base carrier. It comprises of two T-track bars which support a wide range of attachments. Each carrier is supplied with locks for security.



◀ **Detachable tow bar.** The detachable tow bar comes complete with 12N electrics and is easily mounted and detached allowing you to take to the road effortlessly.

Corsavan

Economies of scale.

The small van that gives you more, Corsavan combines car-like levels of driveability and comfort with class-leading 550kg payload capacity. Named *What Van?* Small Van of the Year for 2008, few vans can compete with Corsavan's Group 1E T2 insurance rating, extended service intervals and three-year/60,000 mile warranty.

Compact yet spacious and brilliantly manoeuvrable, Corsavan continues to win praise from the business press. As recently as January 2009, *Commercial Motor* magazine commented: "Corsavan features smooth-as-silk diesel engines and a responsive chassis that will stay composed almost regardless of road conditions". Our customers are equally enthusiastic about the model...



Paul Harris, Fleet Manager, CAMS Fire & Security said... 'We chose the Corsavan because it's neat, it's compact, economical and very reliable. What's more, it performs just like a car, so there are no driveability issues!'



Nigel Boughen, Managing Director, Floor Dimensions Limited said... 'Our running costs have been very good, we regularly get over 500 miles out of a tank of fuel. Plus, our local retailer in Ipswich came up with an unbeatable lease purchase deal.'





Nigel Thorne, Owner of Extreme Signs said... 'In our line of business we needed something that looked great & was economical to own – on occasions we've managed over 60 mpg. And even driven hard, we regularly get over 50mpg'





Front door pockets.



Rev counter.

Safety

Standard features • Driver's dual-stage airbag • Pedal release system – Reduces potential injury to the driver's legs and feet during a severe frontal impact • Laminated windscreen • Side-impact protection beams • Fuel tank located ahead of rear axle • Anti-lock Braking System (ABS) with Electronic Brakeforce Distribution (EBD) – see page 9 • Straight Line Stability control (SLS) – Optimises directional stability when braking • Cornering Brake Control (CBC) – Makes the vehicle easier to control in extreme situations such as braking sharply on a bend • Drag Torque Control (DTC) – Helps maintain stability when suddenly lifting off the accelerator • Emergency Brake Assist (EBA) – Increases brake force applied in emergency braking situations • Adaptive Brake Lights (ABL) – Brake lights flash when ABS is activated, thus warning following vehicles that heavy braking is in progress • Height-adjustable head restraints • Height-adjustable inertia-reel seatbelts • Pyrotechnic body-lock seatbelt pretensioner system – Tightens the diagonal belt during the early stages of a frontal impact • Driver's and passenger's seatbelt force limiters – Reduces potential upper body injuries during a frontal impact • Seatbelt unfastened audible warning • Anti-submarining ramps in seats – Help prevent occupants sliding underneath the lap belt during a collision

Additional features	Corsavan	Sportive
Passenger's dual-stage airbag	○	○
Electronic Stability Programme-plus (ESP-plus) with traction control – see page 9	○	○

Security

Standard features • Electronic theft protection for audio equipment • Electronic engine deadlock immobiliser • 'Key left in ignition' audible warning • Visible Vehicle Identification Number (VIN) • Freewheeling door locks • Door-to-door illumination – Keeps the headlights and rear lights on for 30 seconds after the front doors are locked • Remote control central locking (doors, tailgate, fuel flap) with security deadlocks

Facia, instruments and controls

Standard features • Multi-function display panel showing time, date, audio information and outside air temperature (with ice warning function) • Digital clock with automatic RDS time adjustment • Adjustable speed limit audible warning – Allows the driver to set the speed above which an alarm sounds • Trip odometer • Rev counter • Electronically controlled fuel gauge • Low fuel level warning light • Headlight/brake light bulb failure warning light • Service-due indicator • Handbrake-on warning light • Instrument panel light dimmer • Lights-on audible warning • Electric headlight beam levelling • Glovebox with lid

Additional features	Corsavan	Sportive
Steering column adjustable for reach and rake	□	●
Sports instruments		●

Audio, communication and navigation

Features	Corsavan	Sportive
CD player/stereo radio (CD 30) • CD player • AM/FM stereo radio with 36 station presets • RDS with Traffic Programme • Remote display • 17 watts per channel output • Four speakers	●	●
Satellite navigation/CD player with MP3 format (CD 60) • Satellite navigation system • CD player with MP3 format • Auxiliary-in socket • AM/FM stereo radio with 40 station presets • RDS with Traffic Programme • Remote monochromatic graphic information display • 20 watts per channel output • Four speakers	○	○
Mobile phone system with Bluetooth® (does not include phone or phone-specific cradle) and graphic information display	○	○



CD player/stereo radio (CD 30).

Heating and ventilation

Standard features • Side window demist vents and four adjustable heating and ventilation outlets • Air blend heater with four-speed fan and illuminated controls • Interior pollen filter • Interior odour-reducing activated charcoal filter¹

Additional feature	Corsavan	Sportive
Air conditioning (includes air recirculation facility)	○	●

Seating

Standard features • Reclining front seats • Front passenger's underseat storage tray

Additional features	Corsavan	Sportive
Punch charcoal cloth trim	●	
Twist charcoal cloth trim with red stitching		●
Sports-style seats		●
Driver's seat height adjuster	□	●



Driver's seat height adjuster – standard on Sportive.

Additional interior features

Standard features • Front door pockets • Chrome-effect door handles • Drinks holder and coin holders in centre console • Front tiltable driver's and passenger's assist handles • Dipping rear-view mirror • Interior courtesy light operated by door switches • Chrome-effect handbrake button • Translucent lighting for radio control

Mechanical

Standard features • Front-wheel drive • Five-speed manual gearbox (1.2i 16v, 1.3CDTi 16v (75PS)) • Six-speed manual gearbox (Sportive) • Speed-sensitive electric power-assisted steering – Provides light steering for parking with enhanced feedback at normal road speeds, without harming fuel economy • Gas-pressure dampers • Front anti-roll bar

- = Standard equipment.
- = Optional at extra cost.
- = Only available as part of an extra-cost option pack (see page 20 for details).

¹ = Activated charcoal filter is unavailable on Sportive models and deleted if optional air conditioning is specified.



Front fog lights.



Flush wheel covers.

Load area

Standard features • Glazed tailgate • Half-height steel bulkhead • Loadspace sidewall half-height protection panelling
• Load restraint lashing eyes • Illuminated load area

Additional features	Corsavan	Sportive
Upper load restraint mesh	○	○
Rubber floor mat	○	○
Load compartment cover (four-piece)	○	○

Exterior features

Standard features • Heated rear window • Intermittent rear window wash/wipe • Two-speed windscreen wipers with adjustable intermittent wipe • Tinted glass • Manually foldable door mirrors • High-level LED centre brake light • Rear fog light • Dual Ellipsoidal (DE) halogen headlights • Twin electrically adjustable door mirrors (wide-angle on driver's side) • Body-colour bumpers
• Part body-colour door mirrors • Body-colour tailgate handle

Additional features	Corsavan	Sportive
Electrically operated windows with safety autoreverse and one-touch facility	○	●
Twin electrically heated door mirrors (wide-angle on driver's side)	○	●
Rear parking distance sensors	○	○
Two-coat metallic or pearlescent paint	○	●
Special paint (restrictions apply – please consult your retailer for availability)	○	
Front fog lights	○	●
Dark-style headlights and tail lights		●
Body-colour door handles		●
Dark-tinted rear window		●
Sports exhaust		●

Wheels and tyres

Features	Corsavan	Sportive
Flush wheel covers	●	
14-inch steel wheels with 185/70 R 14 low profile tyres	●	
15-inch alloy wheels with 185/65 R 15 low profile tyres		●
14-inch steel spare wheel	●	●
Tyre inflation kit in lieu of spare wheel	N/C	N/C

Option pack

Plus Pack	Corsavan	Sportive
• Driver's seat height adjuster • Steering column adjustable for reach and rake	○	●

● = Standard equipment.
○ = Optional at extra cost.
N/C = No-cost option.

Engines

	1.2i 16v Twinport ECOTEC-4	1.3CDTi 16v (75PS) ECOTEC-4	1.3CDTi 16v (90PS) ECOTEC-4
Capacity	1229cc	1248cc	1248cc
Maximum power	70PS (51kW) @ 5600rpm	75PS (55kW) @ 4000rpm	90PS (66kW) @ 4000rpm
Maximum torque	115Nm (85 lb.ft.) @ 4000rpm	170Nm (126 lb.ft.) @ 1750-2500rpm	200Nm (147 lb.ft.) @ 1750-2500rpm
Configuration	4 cylinders, 4 valves per cylinder, double overhead camshafts		
Emission compliance	Euro 5		Euro 4
Fuel/induction system	Naturally aspirated with vacuum-controlled Twinport inlet ports. Multi-point sequential electronic fuel injection	Turbocharger with intercooler. Common rail fuel injection	Variable geometry turbocharger with intercooler. Common rail fuel injection
Service interval	20,000 miles or one-year (whichever occurs sooner)		

Weights and towing data

Model	UK plated weights and kerbweights kg						Payload kg	Towing weights Trailer with brakes (without brakes) kg	Plated Gross Combination Weights (GCW) kg
	Front axle		Rear axle		Total				
	Plated	Kerb	Plated	Kerb	GVW	Kerb			
1.2i 16v	815	656	820	409	1615	1065	550	840 (450)	2455
1.2i 16v (a/c)	835	677	820	408	1635	1085	550	820 (450)	2455
1.3CDTi 16v 75PS	900	729	820	411	1690	1140	550	1005 (500)	2695
1.3CDTi 16v 75PS (a/c)	920	750	820	410	1710	1160	550	985 (500)	2695
1.3CDTi 16v 90PS Sportive	920	783	820	407	1740	1190	550	1185 (500)	2925

a/c = Air conditioning.

Note: Kerbweights for standard vehicles include coolant, oil, 90% full fuel tank and spare wheel. They will vary according to the vehicle specification (including options and accessories) with a corresponding variation in payload. **Payload figures** do not allow for the weight of the driver, or any passengers, which should therefore be deducted from the figures shown and are subject to correct weight distribution. **Gross plated weights** (including axle weights) quoted on the vehicle plate must never be exceeded. **Roof load** should not exceed 100kg including the weight of the roof rack/carrier.

Vauxhall Assistance and warranties*

- All new Corsavans qualify for a three-year vehicle warranty consisting of a one-year/unlimited mileage manufacturer's warranty and a second and third year manufacturer's warranty with a 60,000 miles limitation
- Vauxhall Assistance for 12 months from first registration
- Six years' body panel anti-perforation warranty

Fuel economy**

61.9mpg (4.6 litres/100km) unladen.

57.3mpg (4.9 litres/100km) laden.

Important: Figures quoted relate to the particular vehicle tested by an independent organisation. Variations in equipment, payload, driving style, road and traffic conditions, vehicle mileage and standard of maintenance may also affect fuel consumption; therefore the test results do not express or imply any guarantee of fuel consumption attainable.

* = Warranty is only available on vehicles sourced from General Motors UK Limited. Terms and conditions apply – please see your Vauxhall retailer for details.
** = 1.3CDTi 16v (75PS) – obtained during road testing by *Commercial Motor* magazine – May 2007.



Twinport petrol engine.



Common rail turbo diesel engine.



MacPherson strut front suspension.



Compound crank rear suspension.

Steering

- Rack and pinion
- Electric power-assisted steering standard – variable rate on diesel models
- Maximum turning circle (kerb-to-kerb): – 10.10m (33.1ft)

Suspension

Front: Independent. MacPherson struts with gas-pressure damper cartridge and coil springs. Anti-roll bar.

Rear: Compound crank with progressive-rate mini-block coil springs and gas-pressure dampers.

Brakes

- Anti-lock Braking System (ABS)
- Electronic Brakeforce Distribution (EBD)
- Emergency Brake Assist (EBA)
- Cornering Brake Control (CBC)
- Straight Line Stability control (SLS)
- Dual circuit, diagonally split, dual rate servo-assisted system
- Low brake fluid level warning light

1.2i 16v

Front discs: 257mm diameter

Rear drums: 203mm diameter

1.3CDTi 16v (75PS)

Front ventilated discs: 257mm diameter

Rear drums: 228mm diameter

1.3CDTi 16v (90PS)

Front ventilated discs: 284mm diameter

Rear drums: 228mm diameter

Electrics

Alternator:

70A (100A with air conditioning)

Maintenance-free battery:

1.2i 16v – 40Ah (50Ah with air conditioning)

1.3CDTi 16v – 65Ah

Fuel tank capacity

- 45 litres (9.9 gallons)

Body

- Aerodynamic drag co-efficient: Cd 0.33
- Extensive anti-corrosion protection

Insurance group

All models – Group 1E.

As recommended by the Association of British Insurers.

Colour availability

Solid



Glacier White



Flame Red



Cargo Yellow** (special order only)

Two-coat metallic*



Star Silver

Two-coat pearlescent*



Black Sapphire

* = Two-coat metallic and pearlescent colours are available at no extra cost on Sportive models and at extra cost on base models. ** = Not available on Sportive. Special paint options are available on base models. Restrictions apply, please consult your Vauxhall Commercial Vehicle retailer for availability.

Dimensions millimetres (inches)

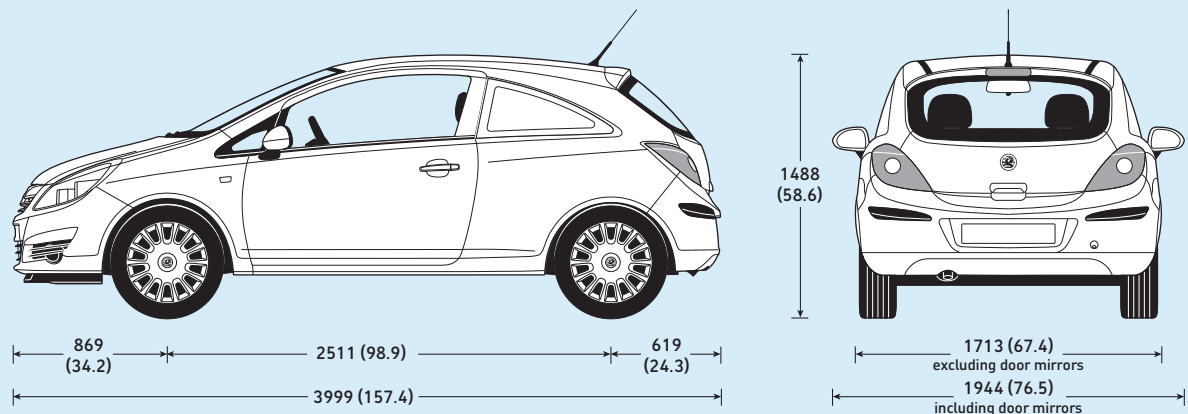

All heights are shown unladen.

Loadspace dimensions

Maximum load length	mm (inches)
Standard vehicle (A)	1257 (49.5)
Maximum load width	
- At widest point (B)	1264 (49.8)
- Between wheel arches (C)	969 (38.1)
Maximum load height	
Standard vehicle (D)*	924 (36.4)
Rear tailgate	
- Maximum aperture height	650 (25.6)
- Maximum aperture width	980 (38.6)
- Load sill height (unladen)	691 (27.2)

* = Without optional load floor mat

Loadspace volume

VDA method	cu.m (cu.ft)
All models	0.92 (32.5)

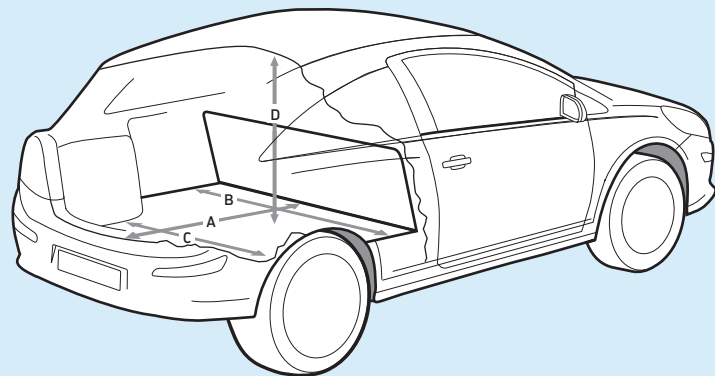

Trust Vauxhall

Protecting the environment

Vauxhall's commitment to the environment is demonstrated by our products' many environmental awards, won both through the use of more recycled materials and by becoming cleaner and more efficient. For information on Vauxhall's efforts to achieve an environmentally sustainable future, see www.vauxhall.co.uk/recycling

Fleet Customer Services

Our dedicated support services for fleet managers includes factory demonstrators and information on whole life costs, company car and van taxation and finance. For further information please call **0870 010 0651**.

Vauxhall Extended Warranty

For complete peace of mind Vauxhall offers an extended warranty that can be purchased on an annual basis following the expiry of the original new vehicle warranty. It covers most mechanical and electrical components. Terms and conditions apply, for further details please contact your local Vauxhall Commercial Vehicle retailer.

Business Lease

Business Lease, from GMAC, offers the versatility of a purchase-based finance plan, while making the most efficient use of tax and cash-flow benefits for VAT-registered business users. It's available for all Vauxhall Commercial Vehicles up to 12 months old and offers highly flexible term lengths, variable deposits and a choice of payment profiles. Ask your retailer for full details.

Business First

Available to business users only, Business First enables you to drive a new vehicle without a large, initial financial outlay. You pay to use the vehicle, not to own it. The vehicle is provided over a predetermined period, and when that period comes to an end the vehicle is returned. Ask your retailer for full details.

Servicing and maintenance

The best way to maximise the performance and reliability of your Vauxhall is to have all routine servicing and maintenance carried out at a Vauxhall Commercial Vehicle retailer. There are over 200 light commercial vehicle and 120 heavy commercial vehicle retailers nationwide.

In the event of an accident...

Vauxhall Accident Support helps keep you mobile following an accident. Benefits include scene-of-accident advice, message service, assistance with claims and vehicle recovery. For further details call **0800 010 304**.

Premier Service Centres

Our Premier Service Centres feature a guaranteed same day repair service (provided the parts are in stock) and an appointment-free service for diagnosis and repairs taking less than 90 minutes. All repairs are carried out within 24 hours of the diagnosis.

For more information...

For a brochure on any Vauxhall model (up to a maximum of three per caller) or location of your nearest retailer, call **0845 600 1500**.

Alternatively, details can be found on our website at: www.vauxhall.co.uk/vans



When you have finished with this brochure please recycle it



- Save up to **£1000*** on a new Vauxhall with The GM Card
- 100 Rebate Points worth **£100** when you use The GM Card for the first time
- Rebate Point saving is on top of any discount or offer negotiated with the Retailer
- Earn 3 Rebate Points (**£3**) for every **£100** you spend

Typical 14.9% APR variable

To apply call **0845 746 2777** or visit www.gmcard.co.uk

The GM Card is issued by HFC Bank Limited and is available to persons aged 18 years or over and resident in the UK (or 21 and over in the Channel Islands) and is subject to status and conditions. Written quotations are available upon request from The GM Card, PO Box 3615, Birmingham B3 2RJ. The typical APR quoted is the rate for new customers. Rebate Points are earned on purchases using The GM Card. Rebate Points are not earned on Balance Transfers or Cash Advances. You earn money off a new Vauxhall by accumulating Rebate Points under the Rebate Points Programme. General Motors UK Limited is solely responsible for the operation of the Rebate Points Programme, which is subject to the Rebate Points Programme Rules. *You can redeem up to 1500 Rebate Points subject to the Model Line Maximum which will vary in amount in relation to different Vauxhall vehicle model lines and unlimited Partner Points. Rebate Points and unlimited Partner Points are redeemable as discounts on a new Vauxhall vehicle and must be redeemed four years from the issue date. Rebate Points may not be redeemed by Motability Contract Hire customers. The GM Card is a trading name and style of both HFC Bank Limited and General Motors UK Limited. HFC Bank registered in England No. 1117305. Registered Office: North Street, Winkfield, Windsor, Berkshire SL4 4TD is authorised and regulated by the Financial Services Authority. Member HSBC Group. HFC Bank Limited is not a member of the same group of companies as General Motors UK Limited or GMAC UK plc. General Motors UK Limited, Registered Office: Griffin House, Osborne Road, Luton, Bedfordshire LU1 3YT. Registered in England number 135767. - CN6/0987.

Every effort has been made to ensure that the contents of this publication were accurate and up-to-date at the time of going to press (December 2009). Vauxhall vehicles are equipped with components manufactured by various General Motors operating units and outside suppliers. The Company reserves the right to alter specifications and withdraw products from sale without notice. Any such alterations will be notified to Vauxhall retailers at the earliest opportunity, please consult your local retailer for the latest information. The specifications detailed within this brochure are not necessarily applicable to alternative models such as Special Editions. Details of any such models will be contained in specific literature or found on the Vauxhall website. Please note that Vauxhall retailers are not the agents of General Motors UK Limited and are not authorised to bind the Company by any specific or implied undertaking or representation. It is advisable to ensure that your motor insurance policy provides adequate cover for additional fitted options and accessories. Please note accessories shown are for illustrative purposes only. As part of Vauxhall's policy of environmental care, this brochure is printed on paper manufactured using Elemental Chlorine Free pulps from specially farmed, sustainable timber resources. All rights reserved. No part of this publication may be reproduced in any form or by any means, without the prior written permission of General Motors UK Limited.

VM0908495 ©General Motors UK Limited 2010 Published January 2010 (BMB/Graymatter) General Motors UK Limited, Luton LU1 3YT

COMMERCIAL VEHICLES
The Wheels of Business



VAUXHALL