

# Astra Estate

2010 Models Edition 2





ASTRA

Astra Design



# Fall in love with driving again.

Choose Astra Estate for its great style, space, flexibility, efficient engines and truly involving chassis. Discover how brilliantly it fits the way you live. And rekindle your passion for driving.

*This brochure covers Astra Estate Life, Club, Design, SXi, SRi and SRi XP models only. Some of the models shown include options and accessories available at extra cost. Not all of the features described are available on every model. So please check in the Equipment section for further details. From time to time, we also offer alternative Astra Estate models such as Special Editions, featured in their own separate literature or found on the Vauxhall website: [www.vauxhall.co.uk](http://www.vauxhall.co.uk)*

Environmental issues 6

Engines and dynamics 8

Safety and security 10

Features and equipment 12

Versatility 14

Astra Estate line-up 16

Accessories 22

Colours and trims 24

Equipment 26

Technical data 32



# Relax in style.

Astra Estate looks as good inside as it does out.  
So just relax and enjoy the ride.







# Respect your world.

We all share a responsibility to look after our world. That's why Vauxhall has been at the forefront of green automotive initiatives for many years. We are always looking to reduce vehicle CO<sub>2</sub> emissions, of course, and our ecoFLEX models like the Astra Estate 1.7CDTi 16v (110PS) have among the lowest vehicle CO<sub>2</sub> emissions in the UK.

But our commitment to preserving the environment goes even further. We are working on even cleaner, alternative power sources, including zero-emission fuel cell technology for example. We have dramatically reduced manufacturing emissions, and our new models use more recycled materials and more recyclable parts than ever before.

We also offer free and easily accessible, environmentally friendly, end-of-life vehicle disposal through our partners Autogreen Ltd.

That way, we reduce our environmental impact in every phase of every vehicle's life cycle. Because your world is our world, too.

**ecoFLEX**

**ecoFLEX engine.** Astra Estate ecoFLEX models feature a 1.7CDTi 16v (110PS) turbo diesel engine and have a CO<sub>2</sub> emissions figure of only 119g/km ensuring eligibility for the lower band C Vehicle Excise Duty charges (correct at the time of going to press).

▼ **6-speed manual transmission.** 1.3CDTi, 1.7CDTi (110PS) and 1.9CDTi diesel models come with a six-speed manual gearbox, helping you make the most of their incredible potential.



◀ **High tech petrols.** Astra Estate comes with a wide range of multi-valve petrol engines. The proven Twinport 1.4i 16v model features a variable intake manifold for strong performance, high fuel efficiency and low emissions. And the two VVT engines – 115PS 1.6i 16v and 140PS 1.8i 16v – use Variable Valve Timing, allowing them to provide most of the maximum torque across a wide rev band. The result? Incredible flexibility through the gears, high power and low fuel consumption.



▼ **Automatic transmission.** Life, Club and Design 1.8i 16v models are available with a four-speed automatic transmission. Design 1.9CDTi (120PS) models can be specified with a sophisticated six-speed variant.



**Efficient turbo diesels.** Common rail fuel injection technology features on all five Astra diesels – the sporty 1.9CDTi (120PS and 150PS), the 1.7CDTi (100PS and 110PS) and the 90PS 1.3CDTi. Superior performance and economy, with low emissions are guaranteed.

**Intelligent ABS.** Astra Estate takes the benefit of standard ABS even further with the inclusion of Cornering Brake Control (CBC), Electronic Brakeforce Distribution (EBD) and Emergency Brake Assist (EBA) as part of the standard system making the car even easier to control and stop in emergency cornering and braking conditions.



▼ **The Sport switch.** Performance to suit your mood. It's like having two cars in one, each with its own unique character and instant switching between the two. Push the button for quicker throttle response and sharper steering, plus sportier gear changes on automatic models.



**Interactive Driving System-plus (IDS-plus).** Available on Astra Estate, as part of the Interactive Driving System with Continuous Damping Control, this clever system senses changes in the vehicle dynamics and automatically adjusts the damper rates – in real time – bringing you confident cornering behaviour and sharper handling with reduced body roll.

*You'll find more information and details of availability for all the features covered on this page in the Equipment and Technical Data section starting on page 26.*



## The ability to thrill.

Every Astra Estate is exciting to drive, striking a careful balance between ride comfort, agility and occupant safety. How do we do it? Through careful chassis tuning and the availability of electronic control systems, like Sport switch, ESP-plus and an IDS-plus system. Astra Estate drivers don't miss out on power, flexibility and economy either, with five economical turbo diesels and three efficient petrol engines available. Whichever you choose, you can be sure of strong response coupled with superb flexibility and tough emissions control.

## The confidence of all-round safety and security.

Whichever model you choose, Astra Estate protects you in so many ways. And it's not just the obvious passive safety features like airbags, ISOFIX child seat fixings and rollover protection. Astra Estate active safety features like Anti-lock Braking System and Cornering Brake Control help prevent accidents in the first place. As you would expect, our security features also look after your belongings as carefully as our safety features look after you.





▶ **Six airbags.** Every Astra Estate front seat comes with front airbags and side-impact airbags – featuring a ‘Thorax-Pelvis’ design to protect more of your body in the event of an impact. Most models also come with full-size curtain airbags as standard.



▶ **Adaptive Forward Lighting (AFL).**

The optional lighting system swivels the headlight beams up to 15 degrees for improved vision as you turn a corner. Above 65mph, it raises the dipped headlight beam slightly, also to increase safety – returning to normal beam automatically as speed is reduced.



**Rear parking distance sensors.**

Available on most trim levels, this clever early warning system helps safeguard your car and pedestrians. When activated, the system beeps as you approach an obstruction, changing to a continuous tone when the object is 300mm away.

**ISOFIX.** Astra Estate’s outer rear seats are pre-fitted with rigid ISOFIX child seat fastening brackets, virtually eliminating the dangers of incorrect child seat installation. For maximum safety, you simply click a compatible Vauxhall ISOFIX accessory child seat into the mounting points engineered in the car.

**Additional security features.** Remote control central deadlocking and an electronic engine immobiliser are standard on every Astra Estate. So is door-to-door illumination, which keeps the dipped headlights and rear lights on for 30 seconds to light your way as you leave a garage or car park.

▶ **Keyless entry and start.** Simply carry the unique system key fob in your pocket or handbag and the car will automatically unlock as you operate a door or the tailgate. To start the engine, you depress the brake pedal and push the start button on the centre console and to stop the engine simply press the button again.



**Active-safety front seat head restraints.**

Activated by the weight of the occupant’s body being forced back into the seat, the active-safety head restraint moves forwards and upright in the event of a rear impact, helping to reduce whiplash injuries. Available as part of the optional Seat Comfort Pack Two on most models.

▶ **Bluetooth®.** With the optional mobile phone system, your phone interfaces with the audio unit, for full operation via the steering wheel controls and fascia display. Bluetooth® wireless connectivity with voice activation is included. Does not include phone or cradle\*.

*\*Please refer to the online Vauxhall Car and Accessory Price Guide for a list of phone-specific cradles.*

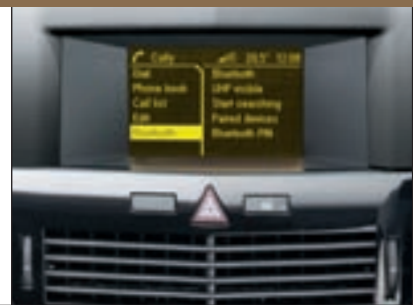

▼ **Cruise control.** The easy-to-use, tap-up tap-down cruise control is available on most Astra Estate models. It allows you to maintain a steady speed without keeping your foot on the throttle. So it's more comfortable on long journeys and easier to keep to speed limits too.

▶ **Satellite navigation.** You'll never get lost in traffic with optional satellite navigation. It can determine your precise location and guide you to your destination by the best and fastest route. The Traffic Message Channel (TMC) function can even change the route according to breaking traffic news.



▼ **Air conditioning and Electronic Climate Control (ECC).** From chilled air on hot days to quicker demisting on damp days, air conditioning makes for a fresher interior environment all year round. And it's standard on virtually every model. Move up to ECC and you can maintain your preferred interior temperature to within a single degree.



▼ **Sensing features.** Headlights that switch on automatically when it gets dark. Wipers that swing into action the moment they sense rain on the windscreen. A rear-view mirror that 'dips' when it detects glare from the car behind. All these features are available within the Astra Estate range.



▼ **Big sounds.** If in-car audio is your thing, look no further. Astra Estate is available with the latest technology including MP3 CD playback and an auxiliary-in socket so you can play tracks direct from your personal MP3 player. There's also an optional system that includes a CD autochanger.





 **Full-length sunroof.** More light, more sunshine, more fresh air. The optional electric slide/tilt glass sunroof extends virtually the entire length of the roof. The front section opens far wider than a typical sunroof. It comes with an interior blind and there's even a multi-position pre-set facility.



## Total control. Total comfort.

Astra Estate's interior space was carefully designed to suit real people of all shapes and sizes. The more relaxed you are, the easier it is to focus on the job in hand. So we've made it easy to find the perfect driving position, your favourite audio choice – even the quickest way home. Wherever you're travelling, it's about total control of your own personal space. In Astra Estate, you can choose more natural light, or more fresh air. You can adjust your interior temperature to the last degree. You can even let the car look after the headlights and windscreen wipers.



## The flexibility to manage your non-stop lifestyle.

Astra Estate has it all. All the space and flexibility to accommodate a non-stop lifestyle. All the same driving excitement. All the comfort, safety and security. Looks that are every bit as dramatic. In fact, everything you love about Astra, with all the loadspace and versatility you'll ever need.



◀ ▼ **FlexOrganiser® Pack.** Sort your luggage space with this clever storage system comprising twin, horizontal rails plus a flexible arrangement of nets and dividers. It's further enhanced with a range of accessories – a side rail strap, divider, side net pocket and storage box.



◀ **Flexible load space.** If you're looking for space, we've got it. A cavernous load area that's as perfect for your business as it is for home and family. Plenty of practical features including a 60/40 split-folding rear seat and a particularly low loading height. And options such as a vertical load-restraining net and a 12-volt accessory socket – great for your accessory coolbox!



▼ **Retractable load area cover.** The easy to operate cover hides your luggage away from prying eyes.



▼ **Load restraint features.** The optional vertical load-restraining net (also part of the Convenience Pack) provides a practical safety solution protecting the occupants from moving loads.



▶ **Spacious load area.** The wide Astra Estate load platform offers up to a generous 470 litres of luggage space, extending to 1550 litres with the rear seats lowered. When you need to pack people and luggage into your Astra, the 60/40 split-folding rear seat back gives you maximum flexibility. Turn to page 35 for further information on the Astra Estate loadspace.

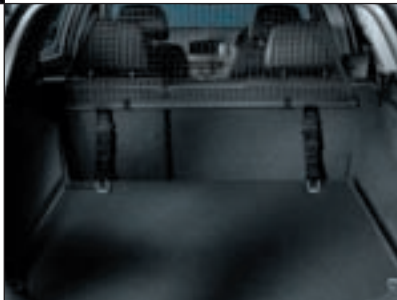

**LIFE****Standard features include:**

- Driver's, front passenger's and front seat side-impact airbags
- Anti-lock Braking System (ABS)
- CD player/stereo radio (CD 30)
- Air conditioning\*
- Driver's seat height adjuster
- Electronic engine deadlock immobiliser
- Steering column adjustable for reach and rake
- Electrically operated front windows
- Service interval monitor
- Body-colour door mirrors
- Remote control central deadlocking
- Multi-function display panel
- Electro-hydraulic power-assisted steering
- Ellipsoid headlights
- Black roof rails
- Retractable luggage compartment cover



| Engine availability         | Insurance groups (ABI) |
|-----------------------------|------------------------|
| 1.4i 16v                    | 9E                     |
| 1.6i 16v VVT                | 12E                    |
| 1.8i 16v VVT                | 15E                    |
| 1.8i 16v VVT automatic      | 15E                    |
| 1.3CDTi 16v (90PS)          | 9E                     |
| 1.7CDTi 16v (100PS)         | 13E                    |
| 1.7CDTi 16v (110PS) ecoFLEX | 14E                    |

\*Non air conditioned models available on 1.4i 16v and 1.3CDTi 16v.

Model illustrated features two-coat metallic paint, optional at extra cost.

Please note: Insurance groups relate to the 50 group rating.





## CLUB

### Standard features include:

- Driver's, front passenger's and front seat side-impact airbags
- Anti-lock Braking System (ABS)
- Steering column adjustable for reach and rake
- Electrically operated front windows
- CD player/stereo radio (CD 30)
- Remote control central deadlocking
- Service interval monitor
- Black roof rails
- Retractable load compartment cover

### Additional features over and above Life model:

- Full-size curtain airbags
- 16-inch Structure wheels (illustrated below left)
- Twin electrically adjustable and heated door mirrors
- Steering wheel mounted audio controls
- Foldable key

| Engine availability         | Insurance groups (ABI) |
|-----------------------------|------------------------|
| 1.4i 16v                    | 10E                    |
| 1.6i 16v VVT                | 13E                    |
| 1.8i 16v VVT                | 16E                    |
| 1.8i 16v VVT automatic      | 16E                    |
| 1.3CDTi 16v (90PS)          | 10E                    |
| 1.7CDTi 16v (100PS)         | 13E                    |
| 1.7CDTi 16v (110PS) ecoFLEX | 14E                    |



Please note: Insurance groups relate to the 50 group rating.

Model illustrated features Smoker Pack (retailer-fit only) and CD player with MP3 format (CD 30 MP3).



## DESIGN

### Standard features include:

- Air conditioning
- Driver's, front passenger's and front seat side-impact airbags
- Full-size curtain airbags
- Anti-lock Braking System (ABS)
- Steering wheel mounted audio controls
- Steering column adjustable for reach and rake
- Remote control central deadlocking

### Additional features over and above Club models:

- Six-way adjustable driver's seat
- Alpha/Morrocana trim
- 16-inch alloy wheels (steel space-saver spare)
- CD player with MP3 format/auxiliary-in socket/stereo radio (CD 30 MP3)
- Multi-function trip computer
- Automatic lighting control
- Electrically operated rear windows
- Front fog lights
- Body-colour side-protection mouldings
- Rain-sensitive windscreen wipers
- Alloy-effect roof rails
- Load area sill protection

### Additional features on 1.9CDTi 16v (150PS) models (illustrated left):

- 17-inch 10-spoke alloy wheels
- Sport switch
- Electronic Stability Programme-plus
- Lowered and uprated sports suspension

*Model illustrated right features electrically operated full-length slide/tilt sunroof and model illustrated left two-coat metallic paint, both optional at extra cost.*



◀ 16-inch alloy wheel.

▶ **Sport Switch.** Standard on 1.9CDTi 16v (150PS) models and optional on all other Design models except ecoFLEX variants.



| Engine availability         | Insurance groups (ABI) |
|-----------------------------|------------------------|
| 1.6i 16v VVT                | 13E                    |
| 1.8i 16v VVT                | 17E                    |
| 1.8i 16v VVT automatic      | 17E                    |
| 1.7CDTi 16v (100PS)         | 14E                    |
| 1.7CDTi 16v (110PS) ecoFLEX | 14E                    |
| 1.9CDTi (120PS)             | 21A                    |
| 1.9CDTi (120PS) automatic   | 21A                    |
| 1.9CDTi 16v (150PS)         | 21A                    |

*Please note: Insurance groups relate to the 50 group rating.*

**SXi**

**Standard features include:**

- Air conditioning
- Driver's, front passenger's and front seat side-impact airbags
- Full-size curtain airbags
- Anti-lock Braking System (ABS)
- Remote control central deadlocking
- Electrically operated front windows
- Foldable key

**Additional features over and above Club models:**

- 16-inch alloy wheels (steel space-saver spare)
- Sports front seats with driver's lumbar adjustment
- CD player with MP3 format/auxiliary-in socket/stereo radio (CD 30 MP3)
- Multi-function trip computer
- Leather-covered sports steering wheel
- Front fog lights
- Body-colour side-protection mouldings



◀ 16-inch alloy wheel.

| Engine availability         | Insurance groups (ABI) |
|-----------------------------|------------------------|
| 1.6i 16v VVT                | 13E                    |
| 1.7CDTi 16v (100PS)         | 13E                    |
| 1.7CDTi 16v (110PS) ecoFLEX | 14E                    |
| 1.9CDTi (120PS)             | 16E                    |

*Model illustrated features Smoker Pack (retailer-fit only), optional at extra cost.*

*Please note: Insurance groups relate to the 50 group rating.*



## SRI

### Standard features include:

- Air conditioning
- Anti-lock Braking System (ABS)
- CD player with MP3 format/auxiliary-in socket/stereo radio (CD 30 MP3)
- Sports front seats with driver's lumbar adjustment
- Multi-function trip computer

### Additional features over and above SXi models:

- 17-inch alloy wheels (steel space-saver spare)
- Remote control ultrasonic security alarm
- Rear spoiler
- Sport switch
- Electronic Stability Programme-plus (ESP-plus) with traction control

### Additional features for SRI models with Exterior Pack:

- 18-inch alloy wheels
- VXR Styling Pack One

| Engine availability | Insurance groups (ABI) |
|---------------------|------------------------|
| 1.8i 16v VVT        | 18E                    |
| 1.7CDTi 16v (100PS) | 13E                    |
| 1.9CDTi (120PS)     | 21E                    |
| 1.9CDTi 16v (150PS) | 21E                    |



▼ 18-inch alloy wheel.

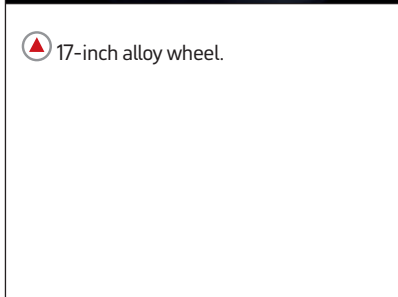

▲ 17-inch alloy wheel.



Please note: Insurance groups relate to the 50 group rating.

Model illustrated features Electronic climate control and Smoker Pack (retailer-fit only), optional at extra cost.

Vauxhall accessories are the right choice for your Astra Estate. Whatever you're into, there's certain to be a Vauxhall accessory with your name on it, all fitted by trained Vauxhall professionals. We've only featured a small selection of what's available here, so please check with your Vauxhall retailer for accessory availability information or visit our website at [www.vauxhall-accessories.com](http://www.vauxhall-accessories.com)



**Floor mats.** Velour floor mats are our premium mat and come with fixing positions to keep them firmly in place. Available in sets of four.



**FURTHER ACCESSORIES AVAILABLE INCLUDE:**

- Thatcham approved alarm system
- Cargo liner
- Mudflaps
- Headlight protectors
- Electrically chilled 12-litre cool bag
- Thule roof boxes
- Thule alloy ski carrier
- Anti-slip mat
- Steering wheel security bar
- Privacy shades
- Child seats
- Alloy wheels
- Rear parking distance sensors
- Fixed or detachable tow bar

**Thule bicycle carrier.** Used in conjunction with the Vauxhall base carrier this system, manufactured by Thule, allows a bicycle to be transported on the roof of your vehicle. Designed to enable easy installation the bicycle is secured using quick release straps and a lock for security. Available in steel or aluminium.

**Base carrier.** The Vauxhall roof rack system begins with a base carrier, comprising two T-track roof bars which support a wide range of attachments. These include a Thule bicycle carrier, Thule ski carrier and choice of high capacity Thule roof boxes. Each one lockable and easy to fit.

**Dog guard\*.** Keep your pet secure in the back of the car and protect the driver and passengers too with our heavy-duty steel dog guard. Custom designed to fit Astra Estate models.



*\*May require additional fitting kit.*

## VAUXHALL ACCESSORY PACKS

Vauxhall accessory packs bring together a selection of essential accessories at great prices, helping you to protect your car and equipping you for roadside emergencies.

*Irmischer*

## Styling

Developed in conjunction with auto design specialists Irmischer International, Astra styling accessories perfectly complement the vehicle's lines, as well as being manufactured to the same exacting standards as the car itself. For availability details please ask your Vauxhall retailer.



▶ **Sports silencer.** For distinctive looks (with chrome-plated tailpipes) and a sportier exhaust note, these split oval design tailpipes are the perfect choice for your Astra.

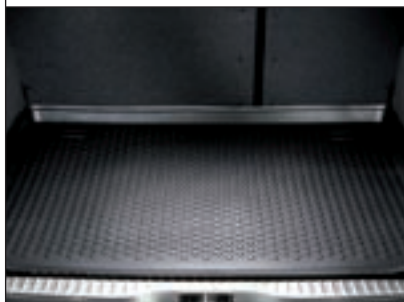

◀ ▶ **Protection Pack.**

- Velour mats
- Mudflaps
- Cargo liner



◀ **Irmischer alloy wheels.** They're the perfect way to personalise your Astra Estate. With a huge range to choose from (style illustrated is Stila), and sizes from 15 to 19 inches, you're sure to find one to suit your style and budget. And don't forget to ask about our accessory wheel locking kits too.

▶ **Safety Pack.**

- First aid kit
- Warning triangle
- Hi-visibility vest



▶ **Cross hatch grille.** Being different is easy with the cross hatch front grille from Irmischer. Featuring an aluminium upper strip with a laser-etched 'Irmischer' logo it adds style and individuality.



Astra Estate's colour and trim combinations have been carefully selected to complement each other, while reflecting the individual status of each trim level in the range.

▶ **Olympic White** – solid



▶ **Power Red** – two-coat solid



▶ **Technical Grey** – two-coat metallic\*



▶ **Sovereign Silver** – two-coat metallic\*



▶ **Metro Blue** – two-coat metallic\*



▶ **Silver Lightning** – two-coat metallic\*



▶ **Ultra Blue** – two-coat pearlescent\*



▶ **Black Sapphire** – two-coat pearlescent\*



▶ **Panacotta** – two-coat pearlescent\*





▶ **Alpha cloth – charcoal**  
*Life*



▶ **Twist cloth – charcoal**  
*Club*

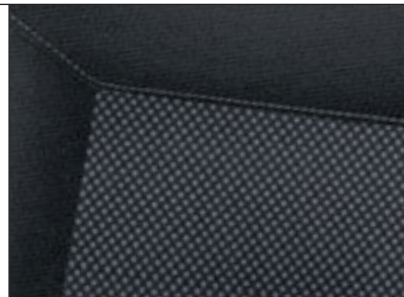

▶ **Alpha cloth/Morrocana – charcoal**  
*Design*



▶ **Silver Alpha cloth – charcoal**  
*SXi/SRi*



▶ **Leather trim\* – charcoal**  
*SXi/SRi*



Colours reproduced on screen may vary slightly from the actual paint colour or trim material. As a result they should be used as a guide only. Your Vauxhall retailer has a comprehensive display of all our paint samples and trim swatches.

\*Optional at extra cost.

## Contents

### Equipment

|                         |    |
|-------------------------|----|
| Safety                  | 26 |
| Security                |    |
| Heating and ventilation |    |

|                                     |    |
|-------------------------------------|----|
| Facia, instruments and controls     | 27 |
| Audio, communication and navigation |    |

|                              |    |
|------------------------------|----|
| Seating and upholstery       | 28 |
| Additional interior features |    |

|                                 |    |
|---------------------------------|----|
| Mechanical                      | 29 |
| Exterior styling and protection |    |

|                                   |    |
|-----------------------------------|----|
| Wheels and tyres                  | 30 |
| Exterior and convenience features |    |

|                   |    |
|-------------------|----|
| Exterior lighting | 31 |
| Option packs      |    |

### Technical data

|   |    |
|---|----|
| Petrol engines  | 32 |
| Petrol engine performance, fuel economy and emissions |    |

|   |    |
|---|----|
| Diesel engines  | 33 |
| Diesel engine performance, fuel economy and emissions |    |

|   |    |
|---|----|
| Vauxhall Assistance and warranties, transmissions, steering, suspension, brakes, fuel tank capacity and weights and towing data | 34 |
|---|----|

|                      |    |
|----------------------|----|
| Exterior dimensions  | 35 |
| Interior dimensions  |    |
| Loadspace dimensions |    |
| Luggage capacities   |    |

## Safety

**Standard features** • Driver's airbag • Front passenger's airbag • Front seat side-impact airbags • Electronic park/brake pedal safety interlock on models with automatic transmission • Energy-absorbing steering column • Pedal release system – Reduces potential injury to the driver's legs and feet during a severe frontal impact • Laminated windscreen • Side-impact protection beams • Integral protective side door padding • Reinforced passenger safety cell

• **ISOFIX child seat restraint system for outer rear seats (does not include child seat)** – Secures ISOFIX child safety seats to the vehicle itself, virtually eliminating the dangers that can result from improper installation • **Child-proof locks on rear doors**

• **Anti-lock Braking System (ABS)** • **Electronic Brakeforce Distribution (EBD)** • **Cornering Brake Control (CBC)** • **Emergency Brake Assist (EBA)** – Increases applied brake force in emergency braking situations

• **Height-adjustable front and outer rear seat head restraints** • **Pyrotechnic front body-lock seatbelt pretensioner system** – Tightens the seatbelt during the early stages of a frontal impact • **Front and outer rear seatbelt force limiters** – Reduces potential upper body injuries during a frontal impact • **Height-adjustable inertia-reel front seatbelts** • **Centre lap and diagonal inertia-reel rear seatbelt** • **Anti-submarining ramps in all seats** – Help prevent occupants sliding underneath the lap belt during a collision

### Additional features

|   | Life | Club | Design         | SXi            | SRI | SRI XP |
|---|------|------|----------------|----------------|-----|--------|
| Electronic Stability Programme-plus (ESP-plus) with traction control <sup>1</sup> | ○    | ○    | ○ <sup>2</sup> | ○ <sup>3</sup> | ●   | ●      |
| Full-size curtain airbags   |      | ●    | ●              | ●              | ●   | ●      |
| Active-safety front seat head restraints  |      | □    | □              | □              | □   | □      |
| Height-adjustable centre rear seat head restraint                                 |      |      |                | □              | □   | □      |

## Security

**Standard features** • Remote control central deadlocking (doors, tailgate, fuel filler flap) • Visible Vehicle Identification Number (VIN) plate • 'Key left in ignition' audible warning • Freewheeling door locks • Electronic engine deadlock immobiliser • Electronic theft protection for audio equipment • Locking wheel bolts for alloy wheels (where fitted) • Driver's internal central locking switch • **Door-to-door illumination** – Keeps the headlights and rear lights on for 30 seconds after the car doors are locked

### Additional features

|   | Life           | Club | Design | SXi | SRI | SRI XP |
|---|----------------|------|--------|-----|-----|--------|
| Keyless entry and start                         |                | ○    | ○      | ○   | ○   | ○      |
| Remote control ultrasonic security alarm system | ○ <sup>4</sup> | ○    | ○      | ○   | ●   | ●      |

## Heating and ventilation

**Standard features** • Air blend heater with four-speed fan • Side window demist vents and adjustable face-level air vents • Interior odour-reducing activated charcoal filter

### Additional features

|  | Life           | Club | Design | SXi | SRI | SRI XP |
|--|----------------|------|--------|-----|-----|--------|
| Air conditioning with air recirculation  | ● <sup>5</sup> | ●    | ●      | ●   | ●   | ●      |
| Electronic Climate Control (ECC) incorporating air conditioning with air recirculation |                | ○    | ○      | ○   | ○   | ○      |

## Facia, instruments and controls

**Standard features** • Rev counter • Multi-function display showing time, date, audio information and outside air temperature (with ice warning function) • Digital clock with automatic RDS time adjustment • Steering column adjustable for reach and rake • Electronic odometer and trip odometer • Instrument panel light dimmer • Handbrake-on/low brake fluid level and low fuel level warning lights • Service interval monitor

### Additional features

|   | Life | Club | Design | SXi | SRI | SRI XP |
|---|------|------|--------|-----|-----|--------|
| Three-spoke steering wheel                        | ●    | ●    |        |     |     |        |
| Three-spoke leather-covered steering wheel        |      |      | ●      |     |     |        |
| Three-spoke leather-covered sports steering wheel |      |      |        | ●   | ●   | ●      |
| Multi-function trip computer                      |      |      | ●      | ●   | ●   | ●      |
| Cruise control                                    |      | ○    | ○      | ○   | ○   | ○      |

## Audio, communication and navigation

### Features

|  | Life           | Club | Design | SXi | SRI | SRI XP |
|--|----------------|------|--------|-----|-----|--------|
| <b>CD player/stereo radio (CD 30)</b><br>• CD player • AM/FM stereo radio with 24 station presets • RDS with Traffic Programme • Remote display • 6 speakers   | ●              | ●    |        |     |     |        |
| <b>CD player with MP3 format/stereo radio (CD 30 MP3)</b><br>• CD player with MP3 format • Auxiliary-in socket • AM/FM stereo radio with 24 station presets • RDS with Traffic Programme • Remote display • 7 speakers   | ○              | ○    | ●      | ●   | ●   | ●      |
| <b>CD autochanger with MP3 format/DAB stereo radio (CDC 40 DAB)</b> (deletes auxiliary-in socket) <sup>6</sup><br>• Integral six-disc CD autochanger with MP3 format • AM/FM/DAB (Digital Audio Broadcast) stereo radio with 36 station presets • RDS with Traffic Programme • Remote graphic information display • 35 watts per channel output • 7 speakers | ○ <sup>7</sup> | ○    | ○      | ○   |     |        |
| <b>CD autochanger with MP3 format/stereo radio (CDC 40)</b> (deletes auxiliary-in socket)<br>• Integral six-disc CD autochanger with MP3 format • AM/FM stereo radio with 36 station presets • RDS with Traffic Programme • Remote graphic information display • 35 watts per channel output • 7 speakers  | ○ <sup>7</sup> | ○    | ○      | ○   | ○   | ○      |
| <b>Satellite navigation/CD player with MP3 format/ stereo radio (CD 70)</b><br>• Satellite navigation system • CD player with MP3 format • Auxiliary-in socket • AM/FM stereo radio with 40 station presets • RDS with Traffic Programme • Remote colour monitor • 20 watts per channel output • 7 speakers  | ○ <sup>8</sup> | ○    | ○      | ○   | ○   | ○      |
| Mobile phone system with Bluetooth® (does not include phone or phone-specific cradle)  | ○ <sup>8</sup> | ○    | ○      | ○   | ○   | ○      |
| Steering wheel mounted audio controls  |                | ●    | ●      | ●   | ●   | ●      |
| Roof-mounted flexible aerial   | ●              | ●    | ●      | ●   | ●   | ●      |



Electronic Stability Programme-plus.



Remote colour monitor (CD 70).

- = Standard equipment
- = Optional at extra cost.
- = Only available as part of an extra-cost option pack (see page 31 for details).
- SRI XP = SRI with Exterior Pack.

- 1 = ESP-plus is switchable on Design models fitted with optional Sports Pack and SRI models.
- 2 = Standard on 1.9CDTi (120PS)/1.9CDTi 16v (150PS) models. Also available as part of an extra-cost option pack
- 3 = Standard on 1.9CDTi (120PS) models.
- 4 = Front and rear reading lights are also included.
- 5 = Non air-conditioned models available on 1.4i 16v/1.3CDTi 16v (90PS)
- 6 = Not available in conjunction with VXR Styling Pack One.
- 7 = Steering wheel mounted audio controls are also included.
- 8 = Steering wheel mounted audio controls and front and rear reading lights are also included.



Lumbar adjustment for driver's seat.



Driver's sunglasses holder.



Electro-chromatic anti-dazzle rear-view mirror.

## Seating and upholstery (see pages 25 for more details)

**Standard features** • Driver's and front passenger's seats with reach and recline adjustment • Driver's seat height adjuster  
• 60/40 split-folding rear seat back

| <b>Additional features</b>  | Life | Club | Design | SXi | SRi | SRi XP |
|---|------|------|--------|-----|-----|--------|
| Alpha cloth seat trim   | ●    |      |        |     |     |        |
| Twist cloth seat trim   |      | ●    |        |     |     |        |
| Alpha cloth seat trim with Morrocana-trimmed side bolsters                            |      |      | ●      |     |     |        |
| Silver Alpha seat trim  |      |      |        | ●   | ●   | ●      |
| Leather seat facings (includes heated front seats with variable temperature settings) |      |      |        | □   | □   | □      |
| Front passenger's seat height adjuster  |      | □    | □      | □   | □   | □      |
| Sports front seats  |      |      |        | ●   | ●   | ●      |
| Lumbar adjustment for driver's seat   |      | □    | ●      | ●   | ●   | ●      |
| Tilt adjustment for driver's seat   |      | □    | ●      | □   | □   | □      |
| Tilt and lumbar adjustment for front passenger's seat                                 |      | □    | □      | □   | □   | □      |

## Additional interior features

**Standard features** • 12-volt auxiliary power socket within centre console • Chrome-effect internal door handles • Fleece velour carpet • Front door pockets • Fully carpeted luggage area • Carpeted rear seat back • Load restraint lashing eyes • Retractable luggage compartment cover • Drinks holder between front seats • Fade up/fade down courtesy lighting operated by front and rear door switches • Illuminated luggage area and glovebox

| <b>Additional features</b>   | Life | Club           | Design         | SXi            | SRi            | SRi XP         |
|--|------|----------------|----------------|----------------|----------------|----------------|
| Matt chrome-effect centre console  | ●    | ●              |                | ●              | ●              | ●              |
| Piano black-effect centre console  |      |                | ●              |                |                |                |
| Charcoal-effect inserts on facia and doors   | ●    |                |                |                |                |                |
| Matt chrome-effect inserts on facia and doors  |      | ●              | ●              |                |                |                |
| Maze chrome-effect inserts on facia and doors  |      |                |                | ●              | ●              | ●              |
| Two rear reading lights and front map reading lights integral with courtesy lights                 |      |                | ●              | ●              | ●              | ●              |
| Driver's sunglasses holder   |      |                | ●              | ●              | ●              | ●              |
| Twin sunvisors incorporating illuminated driver's and front passenger's vanity mirrors with covers |      |                | ●              |                |                |                |
| Electro-chromatic anti-dazzle rear-view mirror   |      |                | ●              |                |                |                |
| 12-volt auxiliary power socket located in luggage compartment                                      |      | □              | □              | □              | □              | □              |
| Vertical load-restraining net  | ○    | ○ <sup>9</sup> | ○ <sup>9</sup> | ○ <sup>9</sup> | ○ <sup>9</sup> | ○ <sup>9</sup> |
| Load area sill protection  |      |                | ●              | ●              | ●              | ●              |

## Mechanical

**Standard features** • Electro-hydraulic power-assisted steering • Lightweight MacPherson strut front suspension and torsion beam rear suspension with gas-pressure dampers • Catalytic converter

| <b>Additional features</b>  | Life | Club | Design          | SXi | SRi | SRi XP |
|---|------|------|-----------------|-----|-----|--------|
| Five-speed manual gearbox (1.4i 16v/1.6i 16v VVT/1.8i 16v VVT/1.7CDTi 16v (100PS))                                      | ●    | ●    | ●               | ●   | ●   | ●      |
| Six-speed manual gearbox (1.3CDTi 16v (90PS)/1.7CDTi 16v (110PS)/1.9CDTi (120PS)/1.9CDTi 16v (150PS))                   | ●    | ●    | ●               | ●   | ●   | ●      |
| Six-speed automatic transmission (1.9CDTi (120PS) only)   |      |      | ○               |     |     |        |
| Four-speed automatic transmission (1.8i 16v VVT only)   | ○    | ○    | ○               |     |     |        |
| Lowered and uprated sports suspension   |      |      | □ <sup>10</sup> |     | ●   | ●      |
| Sport switch  |      |      | □ <sup>10</sup> |     | ●   | ●      |
| Interactive Driving System-plus (IDS-plus) with Continuous Damping Control (CDC) (excludes 1.7CDTi 16v (110PS) ecoFLEX) |      |      | ○ <sup>11</sup> |     | ○   | ○      |

## Exterior styling and protection

| <b>Features</b>  | Life | Club | Design | SXi | SRi | SRi XP |
|--|------|------|--------|-----|-----|--------|
| Dark-tinted Solar Protect <sup>®</sup> glass (excludes windscreen and front door windows)          |      |      | ●      |     | ●   | ●      |
| Airflow optimised front grille and aerodynamic engine undertray (1.7CDTi 16v (110PS) ecoFLEX only) | ●    | ●    | ●      | ●   |     |        |
| Body-colour side-protection mouldings  |      |      | ●      | ●   | ●   | ●      |
| Black foil on door pillars <sup>12</sup>   |      |      | ●      | ●   | ●   | ●      |
| Black door handles   | ●    |      |        |     |     |        |
| Body-colour door handles   |      | ●    | ●      | ●   | ●   | ●      |
| Chrome-effect front door sill covers   |      |      | ●      |     |     |        |
| Chrome-effect window side mouldings  |      |      | ●      |     | ●   | ●      |
| Body-colour door mirrors   | ●    | ●    | ●      | ●   | ●   | ●      |
| Body-colour front lower spoiler, rear lower skirt and side sills                                   |      | □    | □      | □   | □   | ●      |
| Body-colour rear spoiler   |      | □    | □      | □   | ●   | ●      |



Sport switch.



Body-colour rear spoiler.

● = Standard equipment  
 ○ = Optional at extra cost  
 □ = Only available as part of an extra-cost option pack (see page 31 for details).  
 SRi XP = SRi with Exterior Pack.

9 = Also available as part of an extra-cost option pack.  
 10 = Standard on 1.9CDTi 16v (150PS) models.  
 11 = Only available in conjunction with Sports Pack (Sports Pack is standard on 1.9CDTi 16v (150PS) models).  
 12 = Deleted when optional Black Sapphire two-coat pearlescent paint is specified.



17-inch five-spoke alloy wheels.



17-inch 10-spoke alloy wheels.



18-inch five-spoke alloy wheels.

## Wheels and tyres

| Features  | Life | Club | Design          | SXi | SRi             | SRi XP |
|---|------|------|-----------------|-----|-----------------|--------|
| 15-inch steel wheels with flush wheel covers and 195/65 R 15 low profile tyres                                | ●    |      |                 |     |                 |        |
| 16-inch Structure wheels with 205/55 R 16 ultra-low profile tyres   |      | ●    |                 |     |                 |        |
| 16-inch 10-spoke alloy wheels with 205/55 R 16 ultra-low profile tyres  | □    | □    |                 |     |                 |        |
| 16-inch seven twin-spoke alloy wheels with 205/55 R 16 ultra-low profile tyres                                |      |      | ●               |     |                 |        |
| 16-inch twin-spoke alloy wheels with 205/55 R 16 ultra-low profile tyres                                      |      |      |                 | ●   |                 |        |
| 17-inch five-spoke alloy wheels with 225/45 R 17 ultra-low profile tyres                                      |      |      |                 |     | ●               |        |
| 17-inch 10-spoke alloy wheels with 225/45 R 17 ultra-low profile tyres (excludes 1.7CDTi 16v (110PS) ecoFLEX) |      |      | □ <sup>10</sup> |     |                 |        |
| 18-inch five-spoke alloy wheels with 225/40 R 18 ultra-low profile tyres                                      |      |      |                 |     | ○               | ●      |
| Steel space-saver spare wheel/tyre  | ●    | ●    | ●               | ●   | ●               | ●      |
| Full-size steel spare wheel/tyre  | ○    | ○    | ○ <sup>13</sup> | ○   | ○ <sup>14</sup> |        |

## Exterior and convenience features

**Standard features** • Electrically operated front windows with safety autoreverse and one-touch facility • Green-tinted glass • Heated rear window with automatic timed cut-off • Intermittent rear window wash/wipe • Windscreen wipers with variable intermittent facility and flick-wipe • Twin-jet windscreen washer nozzles • Gas-assisted tailgate struts

| Additional features  | Life | Club | Design | SXi | SRi | SRi XP |
|--|------|------|--------|-----|-----|--------|
| Internally adjustable and foldable door mirrors (wide-angle on driver's side)                                      | ●    |      |        |     |     |        |
| Twin electrically adjustable/heated and manually foldable door mirrors (wide-angle on driver's side)               |      | ●    | ●      | ●   | ●   | ●      |
| Twin electrically adjustable/heated and electrically foldable door mirrors (wide-angle on driver's side)           |      | ○    | ○      | ○   | ○   | ○      |
| Electrically operated rear windows with safety autoreverse and one-touch facility                                  |      |      | ●      |     |     |        |
| Folding key (one supplied)   |      | ●    | ●      | ●   | ●   | ●      |
| Electrically operated slide/tilt full-length glass sunroof with multi-position pre-set facility and interior blind |      | ○    | ○      | ○   | ○   | ○      |
| Rain-sensitive windscreen wipers   |      |      | ●      |     |     |        |
| Black roof rails   | ●    | ●    |        | ●   |     |        |
| Alloy-effect roof rails  |      |      | ●      |     | ●   | ●      |
| Two-coat metallic or pearlescent paint   | ○    | ○    | ○      | ○   | ○   | ○      |
| Rear parking distance sensors  |      | ○    | ○      | ○   | ○   | ○      |

## Exterior lighting

**Standard features** • Lights-on audible warning • LED centre brake light • Reversing light, rear fog light, hazard warning lights, side repeat indicators • Ellipsoid headlights • Electric headlight beam levelling

| <b>Additional features</b>   | Life | Club | Design | SXi | SRI | SRI XP |
|--|------|------|--------|-----|-----|--------|
| Chrome-effect headlights   |      | ●    | ●      |     |     |        |
| Dark-style headlights  | ●    |      |        | ●   | ●   | ●      |
| Adaptive Forward Lighting (AFL) incorporating dark-style bi-xenon headlights with dynamic beam levelling and high-pressure washers |      |      | ○      | ○   | ○   | ○      |
| Front fog lights   | □    | □    | ●      | ●   | ●   | ●      |
| Automatic Lighting Control (ALC)   |      |      | ●      |     |     |        |

## Option packs

|   | Life | Club            | Design          | SXi             | SRI             | SRI XP          |
|---|------|-----------------|-----------------|-----------------|-----------------|-----------------|
| <b>Plus Pack</b> • 16-inch 10-spoke alloy wheels with 205/55 R 16 ultra-low profile tyres • Front fog lights  | ○    | ○               |                 |                 |                 |                 |
| <b>Seat Comfort Pack One</b> • Driver's seat with tilt and lumbar adjustment  |      | ○               | ●               | ○               | ○               | ○               |
| <b>Seat Comfort Pack Two</b> • Front passenger's seat with height, tilt and lumbar adjustment • Active-safety front seat head restraints  |      | ○ <sup>15</sup> | ○               | ○ <sup>15</sup> | ○ <sup>15</sup> | ○ <sup>15</sup> |
| <b>Leather Pack</b> • Leather seat facings • Electrically heated sports front seats with tilt and lumbar adjustment • Height-adjustable centre rear seat head restraint • Front passenger's seat height adjuster • Active-safety front seat head restraints |      |                 |                 | ○               | ○               | ○               |
| <b>VXR Styling Pack One</b> (excludes 1.7CDTi 16v (110PS) ecoFLEX) • Body-colour front lower spoiler/rear lower skirt/rear roof spoiler (standard on SRI) and side sills • Aerial adaptor   |      | ○               | ○               | ○               | ○               | ●               |
| <b>Sports Pack</b> (excludes 1.7CDTi 16v (110PS) ecoFLEX) • 17-inch 10-spoke alloy wheels with 225/45 R 17 tyres • Uprated sports steering • Sport switch • Electronic Stability Programme-plus • Lowered and uprated sports suspension                     |      |                 | ○ <sup>10</sup> |                 |                 |                 |
| <b>Convenience Pack</b> • Vertical load-restraining net • 12-volt auxiliary power socket located in luggage compartment   |      | ○               | ○               | ○               | ○               | ○               |
| <b>FlexOrganiser® Pack</b> • Divider net • Four side rails • Elasticated bag with four clips  |      | ○               | ○               | ○               | ○               | ○               |



Electrically foldable door mirrors.



FlexOrganiser® divider net.

- = Standard equipment.
- = Optional at extra cost.
- = Only available as part of an extra-cost option pack.
- SRI XP = SRI with Exterior Pack.

- 10 = Standard on 1.9CDTi 16v (150PS) models.
- 13 = 16-inch spare wheel/tyre supplied if ordered in conjunction with Sports Pack.
- 14 = 16-inch spare wheel/tyre supplied.
- 15 = Only available in conjunction with Seat Comfort Pack One.

Vauxhall supporting



### Smarter driving tips

- **Drive at an appropriate speed:** – Staying within the speed limit increases driver safety, reduces CO<sub>2</sub> emissions and saves fuel. At 70mph you could be using up to 9% more fuel than at 60mph and up to 15% more fuel than at 50mph
- **Drive smoothly at all times:** – Anticipate the ebb and flow of the traffic to avoid harsh acceleration and braking
- **Reduce your revs:** – Change gear earlier to help reduce fuel consumption – try 2500rpm with petrol engines and 2000rpm with diesel
- **Idling is wasting fuel:** – If you're likely to be at a standstill for more than three minutes, switch off the engine to save fuel
- **Regularly check your tyre pressures:** – Under inflated tyres increase CO<sub>2</sub> emissions whilst incorrectly inflated tyres can be unsafe. Always check your handbook for the correct tyre pressure. This will also help to increase the life of your tyres
- **Remove unnecessary items from the car:** – Extra weight increases the engine's workload, whilst roof racks and bike carriers increase wind resistance. All burn more fuel and increase CO<sub>2</sub> emissions

### Petrol engines

|                       | 1.4i 16v ECOTEC-4<br>Twinport  | 1.6i 16v VVT<br>ECOTEC-4   | 1.8i 16v VVT<br>ECOTEC-4   |
|-----------------------|--|--|--|
| Capacity              | 1364cc   | 1598cc   | 1796cc   |
| Maximum power         | 90PS (66kW)<br>@ 5600rpm   | 115PS (85kW)<br>@ 6000rpm  | 140PS (103kW)<br>@ 6300rpm   |
| Maximum torque        | 125Nm (92 lb.ft.)<br>@ 4000rpm   | 155Nm (114 lb.ft.)<br>@ 4000rpm  | 175Nm (129 lb.ft.)*<br>@ 3800rpm   |
| Configuration         | 4 cylinders, 4 valves per cylinder, double overhead camshafts  |  |  |
| Fuel/induction system | Naturally aspirated with vacuum-controlled. Twinport inlet ports. Multi-point sequential fuel injection. | Naturally aspirated. Variable Valve Timing (VVT). Multi-point sequential fuel injection. | Naturally aspirated. Variable Valve Timing (VVT). Multi-point sequential fuel injection. |
| Service interval      | 20,000 miles or 1 year (whichever occurs sooner)   |  |  |

\* = Please note. 1.8i 16v VVT models fitted with optional automatic transmission develop 170Nm (125 lb.ft) of torque.

### Benefit in kind company car taxation rates – 2009/10 tax year

|  |     |     |     |
|--|-----|-----|-----|
| Life, Club, Design, SXi (manual models)      | 17% | 19% | 21% |
| Design with Sports Pack, SRi (manual models) | -   | 19% | 22% |
| All automatic models                         | -   | -   | 25% |

### Petrol engine performance, fuel economy and emissions

|                  | Wheel size (inches) | Performance (manufacturer's figures) |                            |                     | Fuel economy mpg (litres/100km) |                     |                 | CO <sub>2</sub> emissions g/km |
|------------------|---------------------|--------------------------------------|----------------------------|---------------------|---------------------------------|---------------------|-----------------|--------------------------------|
|                  |                     | Maximum speed (mph)                  | Acceleration (sec) 0-60mph | 30-50mph (4th gear) | Urban driving                   | Extra-urban driving | Combined figure |                                |
| <b>Manual</b>    |                     |                                      |                            |                     |                                 |                     |                 |                                |
| 1.4i 16v         | 15/16               | 112                                  | 13.2                       | 9.8                 | 35.3 (8.0)                      | 56.5 (5.0)          | 46.3 (6.1)      | 146                            |
| 1.6i 16v VVT     | 15/16               | 119                                  | 11.2                       | 8.7                 | 32.1 (8.8)                      | 53.3 (5.3)          | 42.8 (6.6)      | 158                            |
| 1.6i 16v VVT     | 17                  | 119                                  | 11.2                       | 8.7                 | 31.7 (8.9)                      | 52.3 (5.4)          | 42.2 (6.7)      | 159                            |
| 1.8i 16v VVT     | 15/16               | 129                                  | 9.8                        | 7.1                 | 29.1 (9.7)                      | 50.4 (5.6)          | 39.8 (7.1)      | 169                            |
| 1.8i 16v VVT     | 17/18               | 129                                  | 9.8                        | 7.1                 | 28.8 (9.8)                      | 49.6 (5.7)          | 39.2 (7.2)      | 172                            |
| <b>Automatic</b> |                     |                                      |                            |                     |                                 |                     |                 |                                |
| 1.8i 16v VVT     | 15/16               | 117                                  | 10.9                       | -                   | 26.9 (10.5)                     | 45.6 (6.2)          | 36.2 (7.8)      | 186                            |
| 1.8i 16v VVT     | 17                  | 117                                  | 10.9                       | -                   | 26.6 (10.6)                     | 44.8 (6.3)          | 35.8 (7.9)      | 189                            |



## Diesel engines

|  | 1.3CDTi 16v<br>ECOTEC-4<br>Turbo diesel                                     | 1.7CDTi 16v (100PS)<br>ECOTEC-4<br>Turbo diesel                     | 1.7CDTi 16v (110PS)<br>ECOTEC-4<br>Turbo diesel                     | 1.9CDTi (120PS)<br>ECOTEC-4<br>Turbo diesel                        | 1.9CDTi 16v (150PS)<br>ECOTEC-4<br>Turbo diesel                     |
|--|---|---|---|--|---|
| Capacity   | 1248cc  | 1686cc  | 1686cc  | 1910cc   | 1910cc  |
| Maximum power  | 90PS (66kW)<br>@ 4000rpm  | 100PS (74kW)<br>@ 4400rpm   | 110PS (81kW)<br>@ 3800rpm   | 120PS (88kW)<br>@ 3500rpm  | 150PS (110kW)<br>@ 4000rpm  |
| Maximum torque   | 200Nm (147 lb.ft.)<br>@ 1750-2500rpm  | 240Nm (177 lb.ft.)<br>@ 2300rpm                                     | 260Nm (192 lb.ft.)<br>@ 2300rpm                                     | 280Nm (206 lb.ft.)<br>@ 2000-2750rpm                               | 320Nm (236 lb.ft.)<br>@ 2000-2750rpm                                |
| Configuration  | 4 cylinders, 4 valves<br>per cylinder, double<br>overhead camshafts         | 4 cylinders, 4 valves<br>per cylinder, double<br>overhead camshafts | 4 cylinders, 4 valves<br>per cylinder, double<br>overhead camshafts | 4 cylinders, 2 valves<br>per cylinder, single<br>overhead camshaft | 4 cylinders, 4 valves<br>per cylinder, double<br>overhead camshafts |
| Fuel/induction system  | Variable geometry turbocharger with intercooler. Common rail fuel injection |   |   |  |   |
| Service interval   | 20,000 miles or 1 year (whichever occurs sooner)                            |   |   |  |   |
| <b>Benefit in kind company car taxation rates – 2009/10 tax year</b> |   |   |   |  |   |
| All manual models  | 18%   | 18%   | 13%   | 20%  | 20%   |
| All automatic models   | -   | -   | -   | 28%  | -   |

## Diesel engine performance, fuel economy and emissions

|                     | Wheel<br>size<br>(inches) | Performance (manufacturer's figures) |   |     | Fuel economy mpg (litres/100km) |                            |                    | CO <sub>2</sub><br>emissions<br>g/km |
|---------------------|---------------------------|--------------------------------------|---|-----|---------------------------------|----------------------------|--------------------|--------------------------------------|
|                     |                           | Maximum<br>speed<br>(mph)            | Acceleration (sec)<br>0-60mph<br>30-50mph<br>(4th gear) |     | Urban<br>driving                | Extra-<br>urban<br>driving | Combined<br>figure |                                      |
| <b>Manual</b>       |                           |                                      |   |     |                                 |                            |                    |                                      |
| 1.3CDTi 16v (90PS)  | 15/16                     | 107                                  | 13.2  | 8.9 | 44.8 (6.3)                      | 68.9 (4.1)                 | 57.6 (4.9)         | 130                                  |
| 1.7CDTi 16v (100PS) | 15                        | 112                                  | 11.7  | 7.5 | 44.1 (6.4)                      | 67.3 (4.2)                 | 56.5 (5.0)         | 135                                  |
| 1.7CDTi 16v (100PS) | 16/17/18                  | 112                                  | 11.7  | 7.5 | 43.5 (6.5)                      | 65.7 (4.3)                 | 55.4 (5.1)         | 138                                  |
| 1.7CDTi 16v (110PS) | 15/16                     | 117                                  | 12.3  | 7.3 | 50.4 (5.6)                      | 72.4 (3.9)                 | 62.8 (4.5)         | 119                                  |
| 1.9CDTi (120PS)     | 16/17/18                  | 120                                  | 10.0  | 6.4 | 39.2 (7.2)                      | 60.1 (4.7)                 | 50.4 (5.6)         | 149                                  |
| 1.9CDTi 16v (150PS) | 16/17/18                  | 129                                  | 8.6   | 6.1 | 39.2 (7.2)                      | 60.1 (4.7)                 | 50.4 (5.6)         | 149                                  |
| <b>Automatic</b>    |                           |                                      |   |     |                                 |                            |                    |                                      |
| 1.9CDTi (120PS)     | 16/17                     | 116                                  | 10.9  | -   | 29.1 (9.7)                      | 52.3 (5.4)                 | 40.4 (7.0)         | 189                                  |

The fuel consumption figures shown comply with EC directive 1999/100 to provide a realistic indication of fuel consumption by taking into account everyday driving conditions, such as cold starts, acceleration, braking and even differences in the weight of models with the same engine. **Important:** the results given relate to the particular car tested; inevitably there are differences between individual cars of the same model. In addition, some cars may incorporate particular modifications. Driving style, road and traffic conditions, vehicle mileage and standard of maintenance may also affect fuel consumption; therefore the results do not express or imply any guarantee of the fuel consumption attainable.



**62.8mpg**

1.7CDTi 16v (110PS) engine offers great economy and low emissions



Common rail turbo diesel engines.

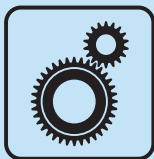

### 4-/5-/6-speed

Manual and automatic transmission options available



MacPherson strut front suspension.

### Vauxhall Assistance and warranties\*

- All new Vauxhalls qualify for a three-year vehicle warranty consisting of a one year/ unlimited mileage manufacturer's warranty and a second and third year manufacturer's warranty with a 60,000 miles limitation
- Vauxhall Assistance for 12 months from first registration
- Six years' body panel anti-perforation warranty

\* = Warranty is only available on vehicles sourced from General Motors UK Limited. Terms and conditions apply – please see your Vauxhall retailer for details.

### Optional transmissions

#### Four-speed automatic transmission – 1.8i 16v VVT models:

Electronically controlled with an adaptive driving programme, which tailors its gearchanges to match your driving conditions.

#### Six-speed automatic transmission with Active Select function – 1.9CDTi (120PS) models:

The electronically controlled adaptive driving function can tailor gearchanges to match your driving style, while the winter mode selects a higher than normal gear to reduce the possibility of wheelspin in icy conditions. The Active Select manual mode allows the gearlever to be used like a manual gearbox – you simply push the lever forward or back to change up or down the gears.

### Steering

- Electro-hydraulic power-assisted steering
- Turning circle (kerb-to-kerb): 11.17m (36.6ft)

### Suspension

**Front:** Independent. Lightweight MacPherson struts with gas-pressure dampers and coil springs. Anti-roll bar.

**Rear:** Lightweight torsion beam rear axle with one-piece, hollow cast trailing arms. Built-in anti-roll bar. Progressive-rate double conical mini-block springs and gas-pressure dampers.

- Design 1.9CDTi 16v (150PS)/SRi models – uprated springs and dampers with lower ride height
- Design/SRi – Interactive Driving System with Continuous Damping Control, optional at extra cost

### Weights and towing data kg

|                              | Gross vehicle weight | Maximum towing weights<br>Trailer with brakes<br>(without brakes) |
|------------------------------|----------------------|---|
| 1.4i 16v Life                | 1810                 | 900 (640)   |
| 1.4i 16v Club                | 1830                 | 900 (640)   |
| 1.6i 16v VVT Life            | 1840                 | 1100 (660)  |
| 1.6i 16v VVT Club/Design/SXi | 1860                 | 1100 (660)  |
| 1.8i 16v VVT Life            | 1850*                | 1300 (660)  |
| 1.8i 16v VVT Club/Design/SRi | 1870*                | 1300 (660)  |
| 1.3CDTi 16v (90PS) Life      | 1905                 | 1300 (690)  |
| 1.3CDTi 16v (90PS) Club      | 1920                 | 1300 (690)  |
| 1.7CDTi 16v (100PS)          | 1950                 | 1400 (690)  |
| 1.7CDTi 16v (110PS)          | 1940                 | 1000 (690)  |
| 1.9CDTi (120PS)              | 1975**               | 1400 (715)  |
| 1.9CDTi 16v (150PS)          | 1990                 | 1400 (720)  |

\* = On 1.8i 16v VVT models with automatic transmission the gross vehicle weight increases by 25kg. \*\* = On 1.9CDTi (120PS) models with automatic transmission the gross vehicle weight increases by 30kg. **Gross vehicle weight** is the total permissible weight of the vehicle including passengers and their luggage. The **maximum roof rack loading** should not exceed 75kg. The **maximum towing weights** are based on the ability of the car, with two occupants of 75kg each, to restart on a 12% gradient, which is approximately 1 in 8.3 at sea level. At altitudes above 1500 metres, the engine output may drop with a corresponding reduction in towing capability. Any extra weight, such as luggage or additional passengers, should be deducted from the maximum towing weight. With a trailer fully loaded, **maximum noseweight** should not exceed 75kg. Always fit Vauxhall towing attachments and accessories available from your Vauxhall retailer. They are designed specifically for Vauxhall models and carry a 12-month guarantee.

### Brakes

- Anti-lock Braking System (ABS)
  - Dual circuit, diagonally split braking system
- 1.4i 16v/1.6i 16v VVT/1.8i 16v VVT/1.3CDTi 16v (90PS)/1.7CDTi 16v (100/110PS)**

Front ventilated discs: 280mm diameter  
Rear discs: 264mm diameter  
**1.9CDTi (120/150PS)**

Front ventilated discs: 308mm diameter  
Rear discs: 264mm diameter

### Fuel tank capacity

52 litres (11.4 gallons).

## Exterior dimensions millimetres (inches)

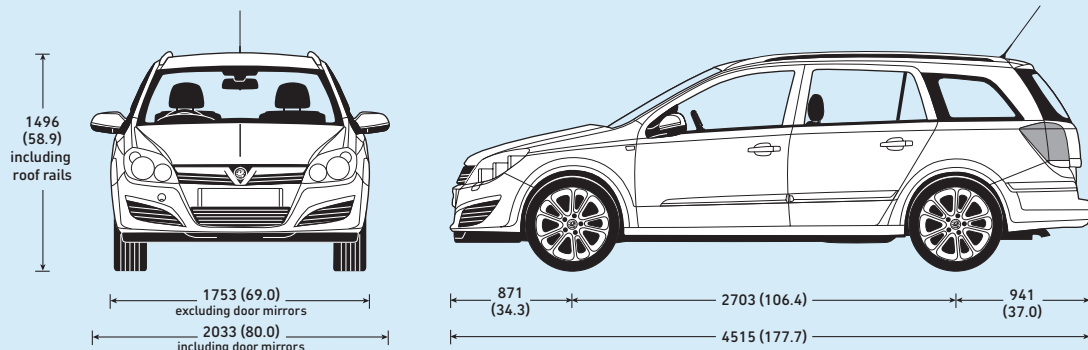

## Interior dimensions see table

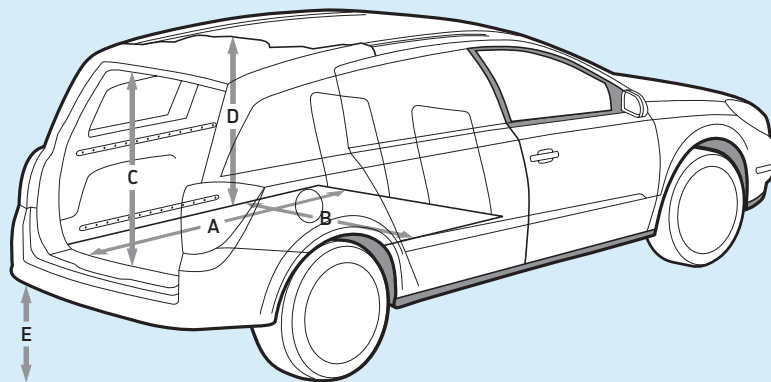

## Loadspace dimensions

|  | mm   | inches |
|--|------|--------|
| Maximum load floor length (rear seats up)                              | 1085 | (42.7) |
| Maximum load floor length (rear seat back down only) (A)               | 1819 | (71.6) |
| Maximum load floor length (rear seat back down and cushion folded) (A) | 1699 | (66.9) |
| Maximum luggage area height (D)  | 862  | (33.9) |
| Tailgate aperture height (C)   | 766  | (30.1) |
| Tailgate aperture width  | 1058 | (41.6) |
| Rear floor width (B)   | 1088 | (42.8) |
| Loading height from ground level (E)                                   | 591  | (23.3) |

## Luggage capacities\*

|  | litres | cu.ft. |
|--|--------|--------|
| Rear seats up – to top of rear seat back | 470    | (16.6) |
| Rear seats folded – to roof              | 1550   | (54.7) |

\* = Measured using the ECIE method.

# Trust Vauxhall

## Protecting the environment

Vauxhall's commitment to the environment is demonstrated by our products' many environmental awards, won both through the use of more recycled materials and by becoming cleaner and more efficient. For information on Vauxhall's efforts to achieve an environmentally sustainable future, see [www.vauxhall.co.uk/recycling](http://www.vauxhall.co.uk/recycling)

## Fleet Customer Services

Our dedicated support services for fleet managers includes factory demonstrators, a three-day test drive programme and information on whole life costs, company car taxation and finance. For further information please call **0870 010 0651**.

## Buying your car

GMAC offers one of the most comprehensive and competitive ranges of financing plans in the UK. Contact your local Vauxhall retailer for details or call the GMAC customer service centre on **0845 712 3444**.

## Vauxhall Extended Warranty

For complete peace of mind Vauxhall offers an extended warranty that can be purchased on an annual basis following the expiry of the original new car warranty. It covers most mechanical and electrical components. Terms and conditions apply, for further details please contact your local Vauxhall retailer.

## Specialist Mobility advice

Motability accredited Vauxhall retailers can provide special mobility help and advice. Blue badge holders are entitled to very favourable discounts on new vehicles. Contact your local Motability accredited Vauxhall retailer or **Freefone 0800 731 5267**.

## Servicing and maintenance

The best way to maximise the performance and reliability of your Vauxhall is to have all routine servicing and maintenance carried out at one of around 400 Vauxhall retailers. To find your nearest retailer call **0845 600 1500**.

## In the event of an accident...

Vauxhall Accident Support helps keep you mobile following an accident. Benefits include scene-of-accident advice, message service, assistance with claims and vehicle recovery. For further details call **0800 010 304**.

## Vauxhall Insurance

Available for new and used Vauxhalls, a Vauxhall Insurance policy offers a unique package designed specifically for Vauxhall drivers. For a highly competitive quotation, call **0844 84 85 840 (Great Britain) or 0845 35 13 410 (N. Ireland)**. Or just visit our website at [www.vauxhall.co.uk](http://www.vauxhall.co.uk)

## For more information...

For a brochure on any Vauxhall model (up to a maximum of three per caller) or location of your nearest Vauxhall retailer please **Lo-call 0845 600 1500**.

Alternatively, details can be found on our website at [www.vauxhall.co.uk](http://www.vauxhall.co.uk)



- Save up to **£1500\*** on a new Vauxhall with The GM Card
- **100 Rebate Points worth £100** when you use The GM Card for the first time
- Rebate Point saving is on top of any discount or offer negotiated with the Retailer
- Earn **3 Rebate Points (£3)** for every **£100** you spend

**Typical 14.9% APR variable**

To apply call **0845 746 2777** or visit [www.gmcard.co.uk](http://www.gmcard.co.uk)



When you have finished with this brochure please recycle it

The GM Card is issued by HFC Bank Limited and is available to persons aged 18 years or over and resident in the UK (or 21 and over in the Channel Islands) and is subject to status and conditions. Written quotations are available upon request from The GM Card, PO Box 3615, Birmingham B3 2RJ. The typical APR quoted is the rate for new customers. Rebate Points are earned on purchases using The GM Card. Rebate Points are not earned on Balance Transfers or Cash Advances. You earn money off a new Vauxhall by accumulating Rebate Points under the Rebate Points Programme. General Motors UK Limited is solely responsible for the operation of the Rebate Points Programme, which is subject to the Rebate Points Programme Rules. \*You can redeem up to 1500 Rebate Points subject to the Model Line Maximum which will vary in amount in relation to different Vauxhall vehicle model lines and unlimited Partner Points. Rebate Points and unlimited Partner Points are redeemable as discounts on a new Vauxhall vehicle and must be redeemed four years from the issue date. Rebate Points may not be redeemed by Motability Contract Hire customers. The GM Card is a trading name and style of both HFC Bank Limited and General Motors UK Limited. HFC Bank registered in England No. 1117305. Registered Office: North Street, Winkfield, Windsor Berkshire SL4 4TD is authorised and regulated by the Financial Services Authority. Member HSBC Group. HFC Bank Limited is not a member of the same group of companies as General Motors UK Limited or GMAC UK plc. General Motors UK Limited, Registered Office: Griffin House, Osborne Road, Luton, Bedfordshire LU1 3YT. Registered in England number 135767. - CN6/0987.

Every effort has been made to ensure that the contents of this publication were accurate and up-to-date at the time of publication (January 2010). Vauxhall vehicles are equipped with components manufactured by various General Motors operating units and outside suppliers. The Company reserves the right to alter specifications and withdraw products from sale without notice. Any such alterations will be notified to Vauxhall retailers at the earliest opportunity, please consult your local retailer for the latest information. The specifications detailed within this brochure are not necessarily applicable to alternative models such as Special Editions. Details of any such models will be contained in specific literature or found on the Vauxhall website. Please note that Vauxhall retailers are not the agents of General Motors UK Limited and are not authorised to bind the Company by any specific or implied undertaking or representation. It is advisable to ensure that your motor insurance policy provides adequate cover for additional fitted options and accessories. Please note accessories shown are for illustrative purposes only. As part of Vauxhall's policy of environmental care, this brochure is printed on paper manufactured using Elemental Chlorine Free pulps from specially farmed, sustainable timber resources. All rights reserved. No part of this publication may be reproduced in any form or by any means, without the prior written permission of General Motors UK Limited.



**VAUXHALL**