

Trust Vauxhall

Protecting the environment

Vauxhall's commitment to the environment is demonstrated by our products' many environmental awards, won both through the use of more recycled materials and by becoming cleaner and more efficient. For information on Vauxhall's efforts to achieve an environmentally sustainable future, see www.vauxhall.co.uk/recycling

Fleet Customer Services

Our dedicated support services for fleet managers includes factory demonstrators, a three-day test drive programme and information on whole life costs, company car taxation and finance. For further information please call **0870 010 0651**.

Buying your car

GMAC offers one of the most comprehensive and competitive ranges of financing plans in the UK. Contact your local Vauxhall retailer for details or call the GMAC customer service centre on **0845 712 3444**.

Sureguard protection

Sureguard Assistance offers the benefits of Vauxhall Assistance for three years from first registration, while Sureguard Warranty also provides a parts and labour warranty for high-mileage or long-term owners. For details contact your local Vauxhall retailer or call **0870 752 7020**.

Specialist Mobility advice

Motability accredited Vauxhall retailers can provide special mobility help and advice. Blue badge holders are entitled to very favourable discounts on new vehicles. Contact your local Motability accredited Vauxhall retailer or **Freefone 0800 731 5267**.

Servicing and maintenance

The best way to maximise the performance and reliability of your Vauxhall is to have all routine servicing and maintenance carried out at one of around 400 Vauxhall retailers. To find your nearest retailer call **0845 600 1500**.

In the event of an accident...

Vauxhall Accident Support helps keep you mobile following an accident. Benefits include scene-of-accident advice, message service, assistance with claims and vehicle recovery. Call **0800 010 304** for a free driver's pack.

Vauxhall Insurance

Available for new and used Vauxhalls, a Vauxhall Insurance policy offers a unique package designed specifically for Vauxhall drivers. For a highly competitive quotation, call **0870 024 0240** or visit our website at www.vauxhall.co.uk

For more information...

For a brochure on any Vauxhall model (up to a maximum of three per caller) or location of your nearest Vauxhall retailer please **Lo-call 0845 600 1500**.

Alternatively, details can be found on our website at www.vauxhall.co.uk

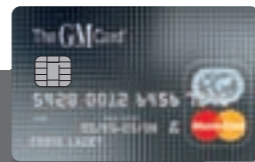

- Save up to £2000* on a new Vauxhall with The GM Card

- 100 Rebate Points worth £100 when you use The GM Card for the first time

- Rebate Point saving is on top of any discount or offer negotiated with the Retailer

- Earn 3 Rebate Points (£3) for every £100 you spend

Typical 14.9% APR variable

To apply call **0845 746 2777** or visit www.gmcard.co.uk.

For a copy of this brochure in large print, Braille or on audio CD, please call 01908 553053 (Mon - Fri 09.00 - 17.00), or via our textphone service on 18001 08456 785 785.

The GM Platinum Card is issued by HFC Bank Limited and is available to persons aged 18 years or over and resident in the UK (or 21 and over in the Channel Islands) and is subject to status and conditions. Written quotations are available upon request from The GM Platinum Card, PO Box 3615, Birmingham B3 2RJ. The typical APR quoted is the rate for new customers. *Rebate Points are earned on purchases using The GM Platinum Card. Rebate Points are not earned on Balance Transfers or Cash Advances. You earn money off a new Vauxhall/Saab by accumulating Rebate Points under the Rebate Points Programme. Vauxhall Motors Ltd is solely responsible for the operation of the Rebate Points Programme, which is subject to the Rebate Points Programme Rules. You can redeem up to 2500 Rebate Points subject to the Model Line Maximum which will vary in amount in relation to different Vauxhall/Saab vehicle model lines and unlimited Partner Points. Rebate Points and unlimited Partner Points are redeemable as discounts on a new Vauxhall/Saab vehicle and must be redeemed four years from the issue date. Rebate Points may not be redeemed by Motability Contract Hire customers. The GM Card is a trading name and style of both HFC Bank Limited and Vauxhall Motors Ltd. HFC Bank registered in England No. 1117305. Registered Office: North Street, Winkfield, Windsor, Berkshire SL4 4TD is authorised and regulated by the Financial Services Authority. **Member HSBC** Group. HFC Bank Limited is not a member of the same group of companies as Vauxhall Motors Ltd, Saab GB Limited or GMAC (UK) plc. Vauxhall Motors Ltd, Registered Office: Griffin House, Osborne Road, Luton, Bedfordshire LU1 3YT. Registered in England number 135767. - CN6/0987.

Every effort has been made to ensure that the contents of this publication were accurate and up-to-date at the time of going to press (September 2007). Vauxhall vehicles are equipped with components manufactured by various General Motors operating units and outside suppliers. The Company reserves the right to alter specifications and withdraw products from sale without notice. Any such alterations will be notified to Vauxhall retailers at the earliest opportunity; please consult your local retailer for the latest information. The specifications detailed within this Special Edition brochure are not necessarily applicable to alternative Corsa, Astra or Zafira models. Details of any such models will be contained in specific literature or found on the Vauxhall website. Please note that Vauxhall retailers are not the agents of Vauxhall Motors Limited and are not authorised to bind the Company by any specific or implied undertaking or representation. It is advisable to ensure that your motor insurance policy provides adequate cover for additional fitted options and accessories. As part of Vauxhall's policy of environmental care, this brochure is printed on paper manufactured using Elemental Chlorine Free pulps from specially farmed, sustainable timber resources. All rights reserved. No part of this publication may be reproduced in any form or by any means, without the prior written permission of Vauxhall Motors Limited.

VM0707352 Published October 2007 (BMB/Graymatter) Vauxhall Motors Limited, Luton LU1 3YT



Breeze Range

2008 Special Edition Models





Corsa Breeze models

4

Astra Sport Hatch Breeze models

6

Astra Hatchback Breeze models

8

Zafira Breeze models

10

Accessories

12

Colours and trims

14

Specification

16

A breath of fresh air

The Breeze range. All your favourite Vauxhall models – with all your favourite features. Brilliant to drive and seriously affordable to own, every Breeze model is packed with all those details that make life better – like air conditioning and steering wheel mounted audio controls. Breeze Plus models add even more. So each has a different personality. Just choose the one that matches your own.

Corsa Breeze

Get a Corsa – get a lot more out of life! With stunning good looks, secure, agile roadholding and a long list of high-value features, Corsa Breeze can't help but make life better. Choose from sporty three-door or versatile five-door models, with punchy petrol and diesel engines, manual or Easytronic transmissions and Breeze or Breeze Plus with its electrically operated sliding sunroof. C'mon!

Standard features include:

- Air conditioning
- Driver's and front passenger's dual-stage airbags
- 15-inch alloy wheels [2]
- Body-colour bumpers
- Stereo radio/CD with MP3 format
- Auxiliary-in socket* [3]
- Steering wheel mounted audio controls
- Steering column adjustable for reach and rake [4]
- Driver's seat height adjuster
- Remote control central deadlocking
- Electrically operated front windows [5]
- Electrically adjustable/heated door mirrors [5]
- Anti-lock Braking System (ABS)
- Charcoal Punch cloth trim

Engine availability

- 1.0i 12v
- 1.2i 16v
- 1.2i 16v Easytronic
- 1.3CDTi 16v (75PS)

Accessory safety kit

Corsa Breeze models also feature an accessory safety kit as standard comprising:

- First aid kit
- Warning triangle
- Hi-visibility vest

* MP3 player not included.



Corsa Breeze Plus

In addition, Breeze Plus models feature the following equipment:

- Electrically operated sliding glass sunroof [1]
- Front passenger's seat height adjuster**

** Deletes front passenger's underseat storage tray.



Astra Sport Hatch Breeze

Great style, a truly involving chassis, power in reserve and serious interior comfort – Astra Sport Hatch is all about excitement. And Breeze models add incredible value to the equation, with air conditioning, a trip computer, MP3 audio playback (from CD or your own MP3 player) and more besides. Breeze Plus steps up to electronic climate control, front fog lights and 16-inch alloys too. Discover how brilliantly it fits the way you live. And fall in love with driving again.

Standard features include:

- Air conditioning
- Six airbags
- 16-inch Structure wheels [3]
- Leather-covered steering wheel
- Body-colour bumpers, door mirrors, door handles and side-protection mouldings
- Stereo radio/CD with MP3 format [4]
- Auxiliary-in socket* [5]
- Steering wheel mounted audio controls [6]
- Multi-function trip computer
- Anti-lock Braking System (ABS)
- Driver's seat height adjuster
- Remote control central deadlocking
- Steering column adjustable for reach and rake
- Charcoal Tabita cloth trim

Engine availability

1.4i 16v

1.6i 16v VVT

1.8i 16v VVT Automatic

1.7CDTi 16v (100PS)

Accessory safety kit

Astra Sport Hatch Breeze models also feature an accessory safety kit as standard comprising:

- First aid kit
- Warning triangle
- Hi-visibility vest

* MP3 player not included.



Astra Sport Hatch Breeze Plus

In addition, Breeze Plus models feature the following equipment:

- 16-inch alloy wheels [1]
- Electronic climate control
- Front fog lights [2]



Astra Hatchback Breeze

Whatever you're up for, Astra Breeze is right there with you, offering great looks, an agile chassis and a five-star EuroNCAP* safety rating. The Astra Breeze five-door hatchback is available with petrol or diesel engines and manual or automatic transmissions. And every one is packed with great features, from air conditioning to remote control deadlocking – with electronic climate control and alloy wheels standard on Breeze Plus models.

* Adult occupant rating.

Standard features include:

- Air conditioning [3]
- Six airbags
- 16-inch Structure wheels [4]
- Leather-covered steering wheel
- Body-colour bumpers, door mirrors, door handles and side-protection mouldings
- Stereo radio/CD with MP3 format
- Auxiliary-in socket**
- Steering wheel mounted audio controls [5]
- Multi-function trip computer
- Anti-lock Braking System (ABS)
- Driver's seat height adjuster [6]
- Remote control central deadlocking
- Chrome-effect interior door handles
- Charcoal Tabita cloth trim

Engine availability

- 1.4i 16v
- 1.6i 16v VVT
- 1.8i 16v VVT Automatic
- 1.7CDTi 16v (100PS)

Accessory safety kit

Astra Breeze models also feature an accessory safety kit as standard comprising:

- First aid kit
- Warning triangle
- Hi-visibility vest

**MP3 player not included.



Astra Breeze Plus

In addition, Breeze Plus models feature the following equipment:

- 16-inch alloy wheels [1]
- Electronic climate control [2]
- Front fog lights



Zafira Breeze

Zafira Breeze. Not only does it carry up to seven people in comfort, but it's bursting with must-have features at a high-value price. Choose Breeze Plus and there's even more – alloy wheels, front fog lights and electronic climate control. Now add Zafira's five-star Euro NCAP* safety rating, Flex7 seating versatility and a dynamic chassis and you've got yet another clever Vauxhall model that truly understands what families are all about.

* Adult occupant rating.

Standard features include:

- Air conditioning [3]
- Six airbags [4]
- 16-inch Structure wheels [5]
- Leather-covered steering wheel [6]
- Dark-tinted glass (excludes windscreen and front door windows)
- Body-colour bumpers, door mirrors, door handles and side-protection mouldings
- Stereo radio/CD player
- Steering wheel mounted audio controls
- Anti-lock Braking System (ABS)
- Aircraft-style handbrake
- Alloy-effect roof rails
- Charcoal Tabita cloth trim

Engine availability

- 1.6i 16v
- 1.8i 16v VVT
- 2.2i 16v Direct Automatic
- 1.9CDTi (120PS)
- 1.9CDTi (120PS) Automatic

Accessory safety kit

Zafira Breeze models also feature an accessory safety kit as standard comprising:

- First aid kit
- Warning triangle
- Hi-visibility vest



Zafira Breeze Plus

In addition, Breeze Plus models feature the following equipment:

- 16-inch alloy wheels [1]
- Electronic climate control [2]
- Front fog lights



Breeze Accessories

Vauxhall retailer-fit accessories are the right choice for your Breeze model. Whatever you're into, there's certain to be a Vauxhall accessory with your name on it all fitted by trained technicians. We've only featured a small selection of what's available here. The Vauxhall Car Accessory Brochure and Car and Accessory Price Guide give further details. Or check out our website at: www.vauxhall-accessories.com



Child seats. Ergonomically styled for comfort and safety, Vauxhall accessory child seats are fixed with standard lap and diagonal seatbelts or the ISOFIX fittings (standard on all Breeze model outer rear* seats). ISOFIX fittings virtually eliminate the dangers of incorrect child seat installation.

*Outer middle row seats on Zafira Breeze.

Base carrier and roof box. The Vauxhall roof rack system begins with a lockable base carrier, comprising two T-track roof bars which support a wide range of attachments. These include a range of bicycle carriers and lockable, easy-to-fit, high capacity roof boxes (available separately).

VXR Styling accessories

Inspired by the hugely successful VXRacing team, VXR styling accessories reflect our experience, knowledge and passion for style and performance. Fitted by your Vauxhall retailer, with the accent firmly on quality and exclusivity, they add flair, personality and excitement to any Breeze model.



VXR Styling accessories. Breathe some extra style into your Breeze model with a front lower spoiler, side sills, rear roof spoiler and rear lower skirt.

Astra rear roof spoiler and front lower spoiler illustrated.

Vauxhall accessory packs bring together a selection of essential accessories at great prices, helping you to protect your car and equipping you for roadside emergencies.

Protection Plus Pack.

- Paint and trim protection
- Velour mats
- Mudflaps



Protection Pack.

- Velour mats
- Mudflaps
- Cargo liner



Breeze Colours and trims

Breeze models are available in a great choice of exterior colours, with cloth trims carefully chosen to complement whichever one you choose. Your Vauxhall retailer has a comprehensive showroom display of all our paint samples and trim swatches, so you can see the real thing before making your mind up.

Due to the limitations of the printing process the colours reproduced may vary slightly from the actual paint colour or trim material. As a result they should be used as a guide only.



Exterior colours

Exterior colours	Model, trim name and trim colours			
	Corsa Punch cloth	Astra Sport Hatch Tabita cloth	Astra Tabita cloth	Zafira Tabita cloth
Solid				
Flame Red	Charcoal	-	-	Charcoal
Power Red – two coat	-	Charcoal	Charcoal	-
Two-coat metallic (optional at extra cost)				
Star Silver	Charcoal	Charcoal	Charcoal	Charcoal
Silver Lightning	Charcoal	Charcoal	Charcoal	Charcoal
Metro Blue	Charcoal	Charcoal	Charcoal	Charcoal
Two-coat pearlescent (optional at extra cost)				
Ultra Blue	Charcoal	Charcoal	Charcoal	Charcoal
Black Sapphire	Charcoal	Charcoal	Charcoal	Charcoal



Front passenger's underseat storage tray.

Driver's seat height adjuster.

Driver's and front passenger's airbags.

Easytronic transmission (optional).

Equipment highlights

- Air conditioning
- 15-inch alloy wheels with 185/65 R 15 low profile tyres (14-inch steel spare)
- Anti-lock Braking System (ABS)
- Driver's and front passenger's dual-stage airbags
- CD 30 MP3 stereo radio/CD player with MP3 format and auxiliary-in socket*
- Steering wheel mounted audio controls
- Steering column adjustable for reach and rake
- Driver's seat height adjuster

* = When using an MP3 player in the car the majority of the controls, such as track selection, remain solely on the player, while only the volume is controlled via the car's regular audio controls.

Breeze Plus model adds

- Electrically operated sliding glass sunroof with interior blind
- Front passenger's seat height adjuster (deletes front passenger's underseat storage tray)

Safety and security

- Deactivation switch for front passenger's airbag
- ISOFIX child seat restraint system for outer rear seats incorporating top tether (does not include child seat)
- Remote control central deadlocking
- Electronic engine deadlock immobiliser
- Door-to-door illumination
- Welcome lighting
- Folding key

Practicality and convenience

- Speed-sensitive power-assisted steering
- Electrically operated front windows
- Intermittent rear window wash/wipe
- Front passenger's underseat storage tray
- Adjustable rear seat backrest
- Stowable luggage compartment cover
- Digital clock with automatic RDS time adjustment
- Lights-on audible warning

Comfort and style

- Satin stone-effect centre console
- Chrome-effect interior door handles and handbrake button
- Interior pollen filter
- Body-colour bumpers and tailgate handle
- Part body-colour electrically adjustable/heated door mirrors
- Tinted glass

Insurance groups

	Breeze	Breeze Plus
1.0i 12v	1E	1E
1.2i 16v	2E	2E
1.3CDTi 16v	3E	3E

As recommended by the Association of British Insurers

Colour and trim availability

See pages 14 and 15 for details.

Fuel tank capacity

- 45 litres (9.9 gallons)

Options at extra cost

- Protection Pack – comprising front seat side-impact airbags/full-size curtain airbags/pyrotechnic front lap belt pretensioner system
- Hill Start Assist Pack – comprising Hill Start Assist/Electronic Stability Programme-plus (ESP-plus)/Deflation Detection System (only available on 1.2i 16v Easytronic models)
- Electronic Stability Programme-plus (ESP-plus)
- ISOFIX child seat restraint system for front passenger's seat (does not include child seat)

Exterior dimensions millimetres (inches)

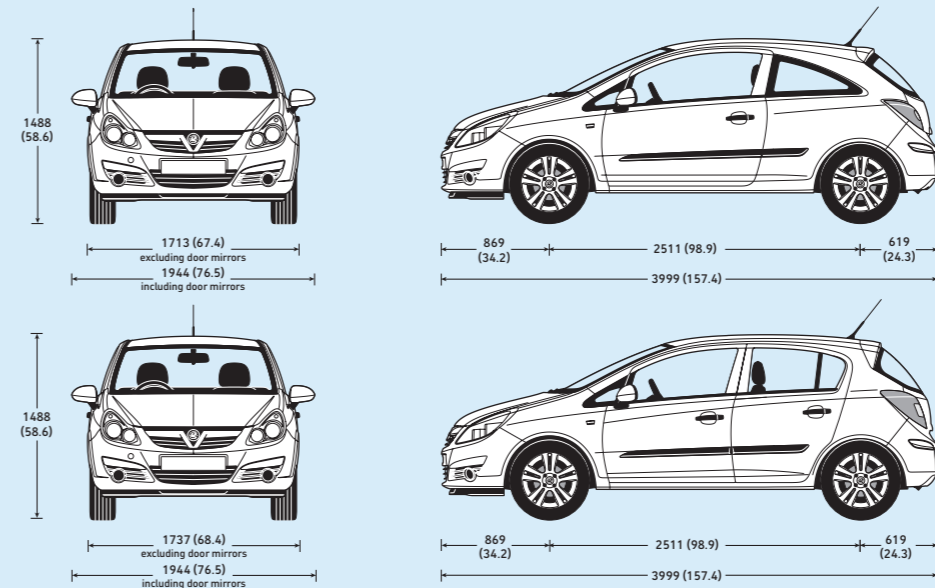

Maximum luggage capacity**

With rear seats up – under luggage compartment cover:

- 3-door – 285 litres (10.0 cu.ft.)
- 5-door – 285 litres (10.0 cu.ft.)

With rear seats folded – to roof:

- 3-door – 1050 litres (37.1 cu.ft.)
- 5-door – 1100 litres (38.8 cu.ft.)

** = measured using the ECIE method.

Engines

1.0i 12v Twinport ECOTEC-Compact petrol (998cc).

Max. power: 60PS (44kW) @ 5600rpm.
Max. torque: 88Nm (65 lb.ft.) @ 3800rpm.

1.2i 16v Twinport ECOTEC-4 petrol (1229cc).

Max. power: 80PS (59kW) @ 5600rpm.
Max. torque: 110Nm (81 lb.ft.) @ 4000rpm.

1.3CDTi 16v (75PS) ECOTEC-4 diesel (1248cc).

Max. power: 75PS (55kW) @ 4000rpm.
Max. torque: 170Nm (126 lb.ft.) @ 1750-2500rpm.

Performance, fuel economy and emissions (manufacturer's figures)

	Performance		Fuel economy mpg (litres/100km)			
	Maximum speed (mph)	Accel. 0-60mph (secs)	Urban driving	Extra-urban driving	Combined figure	CO ₂ emissions (g/km)
1.0i 12v manual	93	17.0	38.7 (7.3)	61.4 (4.6)	50.4 (5.6)	134
1.2i 16v manual	104	13.0	36.7 (7.7)	60.1 (4.7)	48.7 (5.8)	139
1.2i 16v Easytronic	104	14.4	37.2 (7.6)	61.4 (4.6)	49.6 (5.7)	137
1.3CDTi 16v manual	101	13.6	49.6 (5.7)	74.3 (3.8)	62.8 (4.5)	119



Dark-style headlights.

Driver's seat height adjuster.

Keyless entry and start (optional).

Black instruments with chrome edging.

Equipment highlights

- Air conditioning
- 16-inch Structure wheels with 205/55 R 16 ultra-low profile tyres (space-saver spare)
- Lowered and uprated sports suspension
- Dark-style headlights
- Anti-lock Braking System (ABS)
- Multi-function trip computer
- CD 30 MP3 stereo radio/CD with MP3 format
- Auxiliary-in socket*
- Steering wheel mounted audio controls
- Leather-covered steering wheel

* = When using an MP3 player in the car the majority of the controls, such as track selection, remain solely on the player, while only the volume is controlled via the car's regular audio controls.

Breeze Plus model adds

- 16-inch alloy wheels with 205/55 R 16 ultra-low profile tyres (space-saver spare)
- Electronic Climate Control (ECC) incorporating air conditioning
- Front fog lights

Safety and security

- Driver's and front passenger's airbags
- Front seat side-impact airbags
- Full-size curtain airbags
- Remote control central deadlocking
- Electronic engine deadlock immobiliser
- Three lap and diagonal rear seatbelts
- Door-to-door illumination

Practicality and convenience

- Steering column adjustable for reach and rake
- Power-assisted steering
- 60/40 split-folding rear seat back
- Electrically operated front windows
- Intermittent rear window wash/wipe
- Lights-on audible warning

Comfort and style

- Satin stone-effect centre console
- Satin stone-effect inserts on facia and doors
- Chrome-effect interior door handles
- Black instruments with chrome edging
- Driver's seat height adjuster
- Body-colour bumpers and side-protection mouldings
- Body-colour door handles
- Body-colour electrically adjustable/heated door mirrors
- Green-tinted glass
- Black foil on door pillars (deleted when optional Black Sapphire paint is specified)

Insurance groups

	Breeze	Breeze Plus
1.4i 16v	5E	5E
1.6i 16v	7E	7E
1.8i 16v	7E	7E
1.7CDTi 16v	6E	6E

As recommended by the Association of British Insurers

Colour and trim availability

See pages 14 and 15 for details.

Fuel tank capacity

- 52 litres (11.4 gallons)

Options at extra cost

- Seat Comfort Pack One – comprising driver's seat with tilt and lumbar adjustment
- Seat Comfort Pack Two – comprising front passenger's seat with tilt and lumbar adjustment (requires Seat Comfort Pack One)
- Electronic Stability Programme-plus (ESP-plus)
- CDC 40 DAB stereo radio/six-disc CD autochanger with MP3 format
- Cruise control
- Keyless entry and start
- Remote control ultrasonic security alarm
- Mobile phone system with Bluetooth® (does not include phone or cradle)

Exterior dimensions millimetres (inches)

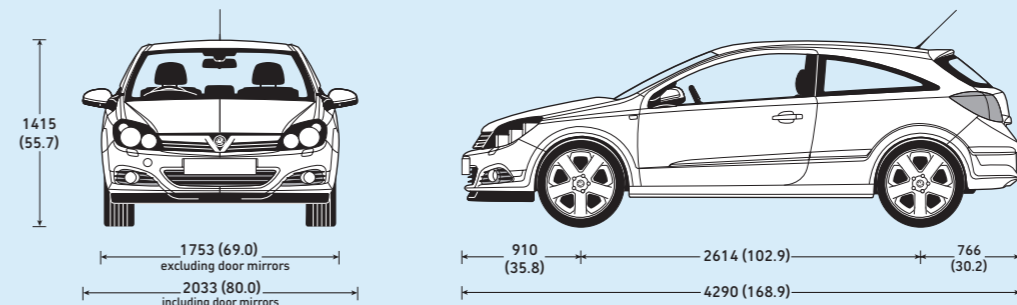

Maximum luggage capacity**

With rear seats up – to top of rear seat back:

- 312 litres (11.0 cu.ft.)

With rear seats folded – to roof:

- 1070 litres (37.8 cu.ft.)

** = measured using the ECIE method.

Engines

1.4i 16v Twinport ECOTEC-4 petrol (1364cc).
Max. power: 90PS (66kW) @ 5600rpm.
Max. torque: 125Nm (92 lb.ft.) @ 4000rpm.

1.6i 16v VVT ECOTEC-4 petrol (1598cc).
Max. power: 115PS (85kW) @ 6000rpm.
Max. torque: 155Nm (114 lb.ft.) @ 4000rpm.

1.8i 16v VVT ECOTEC-4 petrol (1796cc)†
Max. power: 140PS (103kW) @ 6300rpm.
Max. torque: 170Nm (125 lb.ft.) @ 3800rpm.

1.7CDTi 16v ECOTEC-4 diesel (1686cc).
Max. power: 100PS (74kW) @ 4400rpm.
Max. torque: 240Nm (177 lb.ft.) @ 2300rpm.

† = Only available in conjunction with automatic transmission.

Performance, fuel economy and emissions (manufacturer's figures)

	Performance		Fuel economy mpg (litres/100km)			
	Maximum speed (mph)	Accel. 0-60mph (secs)	Urban driving	Extra-urban driving	Combined figure	CO ₂ emissions (g/km)
1.4i 16v manual	112	12.7	35.3 (8.0)	56.5 (5.0)	46.3 (6.1)	146
1.6i 16v manual	120	10.8	32.5 (8.7)	54.3 (5.2)	43.5 (6.5)	156
1.8i 16v automatic	118	10.5	27.2 (10.4)	46.3 (6.1)	36.7 (7.7)	185
1.7CDTi 16v manual	113	11.4	44.1 (6.4)	67.3 (4.2)	56.5 (5.0)	135

Please note: Further specification details for the Astra Sport Hatch range appear in the Astra 2008 main brochure.



Mobile phone system with Bluetooth® (optional).



Driver's seat height adjuster.



Black instruments with chrome edging.



Cruise control (optional).

Equipment highlights

- Air conditioning
- 16-inch Structure wheels with 205/55 R 16 ultra-low profile tyres (space-saver spare)
- Anti-lock Braking System (ABS)
- Multi-function trip computer
- CD 30 MP3 stereo radio/CD with MP3 format
- Auxiliary-in socket*
- Steering wheel mounted audio controls
- Leather-covered steering wheel

* = When using an MP3 player in the car the majority of the controls, such as track selection, remain solely on the player, while only the volume is controlled via the car's regular audio controls.

Breeze Plus model adds

- 16-inch alloy wheels with 205/55 R 16 ultra-low profile tyres (space-saver spare)
- Electronic Climate Control (ECC) incorporating air conditioning
- Front fog lights

Safety and security

- Euro NCAP five-star** (adult occupant rating)
- Driver's and front passenger's airbags
- Front seat side-impact airbags
- Full-size curtain airbags
- Remote control central deadlocking
- Electronic engine deadlock immobiliser
- Three lap and diagonal rear seatbelts
- Door-to-door illumination

** = Achieved for Astra 5-door hatchback tested.

Practicality and convenience

- Steering column adjustable for reach and rake
- Power-assisted steering
- 60/40 split-folding rear seat back
- Electrically operated front windows
- Intermittent rear window wash/wipe
- Lights-on audible warning

Comfort and style

- Satin stone-effect centre console
- Satin stone-effect inserts on facia and doors
- Chrome-effect interior door handles
- Black instruments with chrome edging
- Driver's seat height adjuster
- Body-colour bumpers and side-protection mouldings
- Body-colour door handles
- Body-colour electrically adjustable/heated door mirrors
- Green-tinted glass

Insurance groups

	Breeze	Breeze Plus
1.4i 16v	5E	5E
1.6i 16v	7E	7E
1.8i 16v	7E	7E
1.7CDTi 16v	6E	6E

As recommended by the Association of British Insurers

Colour and trim availability

See pages 14 and 15 for details.

Fuel tank capacity

- 52 litres (11.4 gallons)

Options at extra cost

- Seat Comfort Pack One – comprising driver's seat with tilt and lumbar adjustment
- Seat Comfort Pack Two – comprising front passenger's seat with tilt and lumbar adjustment (requires Seat Comfort Pack One)
- Electronic Stability Programme-plus (ESP-plus)
- CDC 40 DAB stereo radio/six-disc CD autochanger with MP3 format
- Cruise control
- Keyless entry and start
- Remote control ultrasonic security alarm
- Mobile phone system with Bluetooth® (does not include phone or cradle)

Exterior dimensions millimetres (inches)

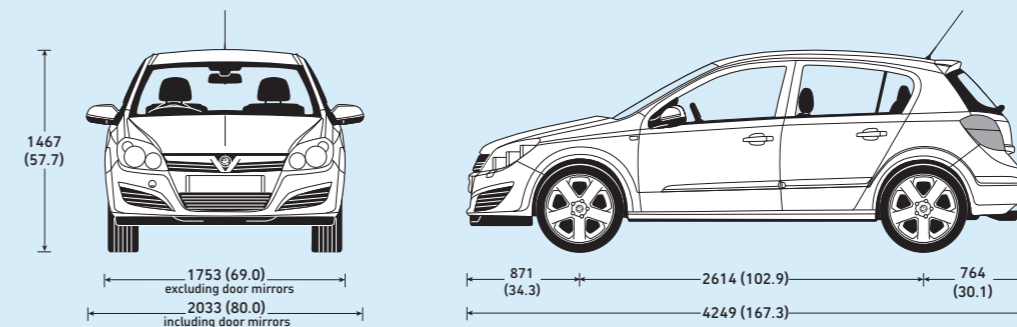

Maximum luggage capacity†

With rear seats up – to top of rear seat back:

- 350 litres (12.4 cu.ft.)

With rear seats folded – to roof:

- 1265 litres (44.7 cu.ft.)

† = measured using the ECIE method.

Engines

1.4i 16v Twinport ECOTEC-4 petrol (1364cc).
Max. power: 90PS (66kW) @ 5600rpm.
Max. torque: 125Nm (92 lb.ft.) @ 4000rpm.

1.6i 16v VVT ECOTEC-4 petrol (1598cc).
Max. power: 115PS (85kW) @ 6000rpm.
Max. torque: 155Nm (114 lb.ft.) @ 4000rpm.

1.8i 16v VVT ECOTEC-4 petrol (1796cc)††
Max. power: 140PS (103kW) @ 6300rpm.
Max. torque: 170Nm (125 lb.ft.) @ 3800rpm.

1.7CDTi 16v ECOTEC-4 diesel (1686cc).
Max. power: 100PS (74kW) @ 4400rpm.
Max. torque: 240Nm (177 lb.ft.) @ 2300rpm.

†† = Only available in conjunction with automatic transmission.

Performance, fuel economy and emissions (manufacturer's figures)

	Performance		Fuel economy mpg (litres/100km)			
	Maximum speed (mph)	Accel. 0-60mph (secs)	Urban driving	Extra-urban driving	Combined figure	CO ₂ emissions (g/km)
1.4i 16v manual	112	12.8	35.3 (8.0)	56.5 (5.0)	46.3 (6.1)	146
1.6i 16v manual	119	10.9	32.5 (8.7)	54.3 (5.2)	43.5 (6.5)	156
1.8i 16v automatic	117	10.7	26.9 (10.5)	45.6 (6.2)	36.2 (7.8)	187
1.7CDTi 16v manual	112	11.5	43.5 (6.5)	65.7 (4.3)	55.4 (5.1)	138

Please note: Further specification details for the Astra range appear in the Astra 2008 main brochure.



Steering wheel mounted audio controls.



Driver's and front passenger's front and side-impact airbags.



Air conditioning.



Remote control security alarm (optional).

Equipment highlights

- Air conditioning
- 16-inch Structure wheels with 205/55 R 16 ultra-low profile tyres (emergency tyre inflation kit in lieu of spare wheel)
- Anti-lock Braking System (ABS)
- Dark-tinted glass (excludes windscreen and front door windows)
- Multi-function trip computer
- CD 30 stereo radio/CD player
- Steering wheel mounted audio controls
- Leather-covered steering wheel
- Body-colour electrically adjustable/heated door mirrors

Breeze Plus model adds

- 16-inch alloy wheels with 205/55 R 16 ultra-low profile tyres (emergency tyre inflation kit in lieu of spare wheel)
- Electronic Climate Control (ECC) incorporating air conditioning
- Front fog lights

Safety and security

- Euro NCAP five-star (adult occupant rating)
- Driver's and front passenger's front and side-impact airbags
- Full-size front and second-row curtain airbags
- Front seatbelt force limiters
- Lap and diagonal inertia-reel seatbelts on all seats
- ISOFIX child seat system for outer second-row seats (does not include child seat)
- Remote control central deadlocking
- Electronic engine deadlock immobiliser

Practicality and convenience

- Flex7 seating
- Multi-function trip computer
- 40/20/40 split-folding second-row seat back
- Second-row seats with sliding function plus fold and stow facility
- Two individual fold-flat third-row seats
- Steering column adjustable for reach and rake
- Alloy-effect roof rails

Comfort and style

- Charcoal metallic-effect centre console
- Microtech Silver inserts on facia and doors
- Chrome-effect interior door handles
- Driver's seat height adjuster
- Second-row passenger compartment heating outlets
- Black instrument dials with chrome edging
- Body-colour door and tailgate handles, bumpers and side-protection mouldings

Insurance groups

	Breeze	Breeze Plus
1.6i 16v	5E	5E
1.8i 16v	8E	8E
2.2i 16v	9E	9E
1.9CDTi (120PS)	7E	7E

As recommended by the Association of British Insurers

Colour and trim availability

See pages 14 and 15 for details.

Fuel tank capacity

- 58 litres (12.8 gallons)

Options at extra cost

- FlexOrganiser® Pack – comprising 3D storage net/side net pocket/four side rail hooks/four side rails
- Electronic Stability Programme-plus (standard on 2.2i 16v)
- Cruise control
- Full-size steel spare wheel (in lieu of emergency tyre inflation kit)
- Vertical load-restraining net
- Front and rear parking distance sensors
- Keyless entry and start
- Remote control ultrasonic security alarm
- CDC 40 stereo radio with Digital Audio Broadcast (DAB)/integral six-disc CD autochanger with MP3 format/auxiliary-in socket
- Rear seat Twin Audio® system with single headset (requires CDC 40, deletes auxiliary-in socket)
- Mobile phone system with Bluetooth® (does not include phone or cradle)

Exterior dimensions millimetres (inches)

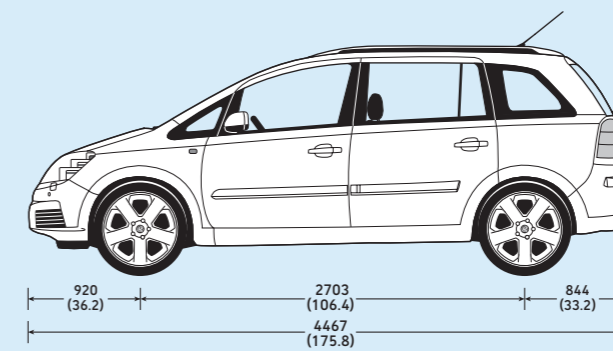
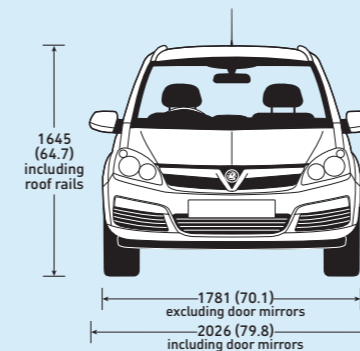

Engines

1.6i 16v Twinport ECOTEC-4 petrol (1598cc).
Max. power: 105PS (77kW) @ 6000rpm.
Max. torque: 150Nm (111 lb.ft.) @ 3900rpm

1.8i 16v VVT ECOTEC-4 petrol (1796cc).
Max. power: 140PS (103kW) @ 6300rpm.
Max. torque: 175Nm (129 lb.ft.) @ 3800rpm.

2.2i 16v Direct ECOTEC-4 petrol (2198cc).**
Max. power: 150PS (110kW) @ 5600rpm.
Max. torque: 215Nm (159 lb.ft.) @ 4000rpm.

1.9CDTi ECOTEC-4 diesel (1910cc).
Max. power: 120PS (88kW) @ 3500rpm.
Max. torque: 280Nm (206 lb.ft.) @ 2000-2750rpm.

** = Only available in conjunction with automatic transmission.

Performance, fuel economy and emissions (manufacturer's figures)

	Performance		Fuel economy mpg (litres/100km)			
	Maximum speed (mph)	Accel. 0-60mph (secs)	Urban driving	Extra-urban driving	Combined figure	CO ₂ emissions (g/km)
1.6i 16v manual	110	13.3	29.7 (9.5)	47.1 (6.0)	38.7 (7.3)	175
1.8i 16v manual	122	10.8	27.4 (10.3)	44.1 (6.4)	36.2 (7.8)	187
2.2i 16v automatic	118	10.8	24.4 (11.6)	42.2 (6.7)	33.2 (8.5)	204
1.9CDTi manual	116	11.4	37.2 (7.6)	55.4 (5.1)	47.1 (6.0)	162
1.9CDTi automatic	113	11.7	28.8 (9.8)	49.6 (5.7)	39.2 (7.2)	194

Maximum luggage capacity*

Behind second-row seats – to glass line:

- 645 litres (22.8 cu.ft.)
- With rear seats folded flat – to roof:
- 1820 litres (64.3 cu.ft.)

* = measured using the ECIE method.

Loadspace dimensions

millimetres (inches)

Maximum load floor length (behind front seats†)	1809 (71.2)
Maximum load floor length (behind front seats††)	1525 (60.0)
Maximum load floor length (behind second-row seat)	1088 (42.8)
Maximum load floor length (behind third-row seat)	405 (15.9)
Maximum load floor width	1114 (43.9)
Width between wheel arches	1071 (42.2)
Tailgate aperture height	893 (35.2)
Tailgate aperture width	1136 (44.7)

† = Second-row seat back lowered
†† = Second-row seat folded and stowed

Please note: Further specification details for the Zafira range appear in the Zafira 2008 main brochure.